

**SNACKSHOP 5000**

**SNACKSHOP 5000**

**SNACKSHOP 5000**

**instruction manual for**

**SNACKSHOP 5000**

*Automatic* **PRODUCTS COMPANY**  
76 WEST PLATO BOULEVARD • ST. PAUL, MINNESOTA 55107

	Page
WARRANTY .....	1
SPECIFICATIONS .....	1
CAPACITIES .....	2
UNPACKING .....	3
INSTALLATION .....	3-6
COMPONENTS .....	7
1. Power Supply .....	7
2. Changer .....	7
3. Mode Switch Box .....	7
4. Selection Panel and Control Board .....	7
5. Vend Motors .....	8
6. Price Checking Without M.I.S. ....	9
7. Management Information System .....	9-10
8. Price Setting Using M.I.S. and Product Code .....	10
9. Price Check Using M.I.S. ....	10
10. Cash Accountability .....	10-11
11. Test Vend Mode Operation .....	11
12. Machine Identification Number .....	11
13. Service Diagnostic Display .....	11-12
14. Use of M.I.S. ....	12-13
15. Lighting System .....	13
16. Main Product Shelves .....	13
17. Delivery Bin .....	13-14
18. Coin Return .....	14
19. Coin Acceptance .....	14
20. Gum and Mint Mechanism .....	14
21. Gum and Mint Motors .....	14
22. Gum and Mint Empty Switches .....	14
23. Sliding Panel Removal and Installation .....	14
CLEANING .....	14
OPTIONAL EQUIPMENT .....	
1. Ventilating Fan .....	15
2. Utilization Kits .....	15
3. Gum and Mint .....	15
4. Soup Dispenser .....	15
TROUBLESHOOTING .....	15
PARTS LIST .....	
1. Cabinet .....	20-21
2. Connectors .....	26
3. Delivery Bin .....	26
4. Door—Front Panels and Stylings .....	29-35
5. Door—Inside Front .....	18-19
6. Door—Outside Front .....	16-17
7. Electrical Harnesses .....	28
8. Gum & Mint Panel .....	22-23
9. Main Button and Panel Assembly .....	27
10. Main Interlock Box .....	28
11. Product Shelves .....	24-25

Technical information is available free of charge to our customers at [www.automaticproducts.com](http://www.automaticproducts.com)

## WARRANTY

The Automatic Products Company warrants this vendor, manufactured by it, to be free from defects in material or workmanship under normal use. Our obligation under this warranty is to the original purchaser only and is limited to making good at our factory any part or parts thereof which shall, within two (2) years after delivery of such product to the original purchaser, be returned to us or to our authorized dealer or distributor from whom purchased with all transportation charges prepaid to our factory, and which our examination shall disclose to our satisfaction to have been defective.

This warranty does not extend: 1: To any of our products which have been subjected to misuse, neglect, accident, incorrect wiring, improper installation, or to use in violation of instructions furnished by us; 2: To units which have been repaired or altered outside of our factory; 3: To cases where the serial number of the product has been removed, defaced or changed; 4: To electrical components, lamps, tubes or circuit breakers; 5: To accessories not of our own manufacture used with our products. Any part manufactured by Automatic Products Company, found by us to be defective within the warranty period will be exchanged by Automatic Products Company or their

authorized dealer or distributor without charge to the owner.

This warranty applies only to our products which are used within the United States of America, and is in lieu of all warranties expressed or implied, including, but not limited to implied warranties of merchantability or fitness for a particular purpose, and no representative or person is authorized to assume for us any other liability in connection with the sale of our products.

The Automatic Products Company reserves the right to make any changes or improvements in its products without notice and without obligation, and without being required to make corresponding changes or improvements in products theretofore manufactured or sold.

AUTOMATIC PRODUCTS COMPANY  
75 West Plato Boulevard  
St. Paul, Minnesota 55107

Snackshop 5000 has been designed from superior engineering and with quality throughout. It has been built of rugged construction for many years of reliable trouble-free operation.

To achieve the most economical trouble-free operation from your Snackshop 5000, it is recommended that this service manual be thoroughly read and instructions followed pertaining to all loading and servicing, etc., of the vendor.

Should you have questions pertaining to this manual or the vendor, please contact your local Automatic Products Company distributor or write directly to:

Service Manager  
Automatic Products Company  
75 West Plato Boulevard  
St. Paul, Minnesota 55107

## SPECIFICATIONS

HEIGHT - 72"      WIDTH - 33"      DEPTH - 27 1/2"  
FLOOR SPACE REQUIRED - 6.5 SQ. FT.  
SHIPPING CONTAINER SIZE - 72.5 CU. FT.  
POWER REQUIREMENTS - 115 V., 60 HZ.  
STANDBY AMPERES - .7      OPERATING AMPERES - 3

## capacities

Unless otherwise specified machine will be shipped with spiral assortment shown below.  
 Figures in circles represent capacities in each spiral.

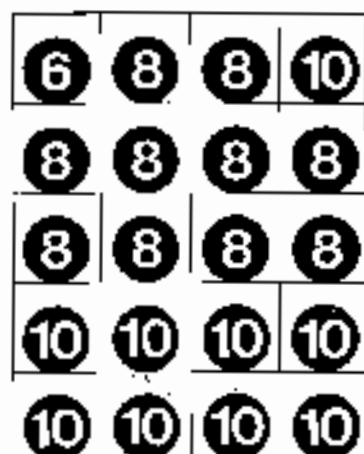

MODEL 5520

Capacity as shown: 176 units

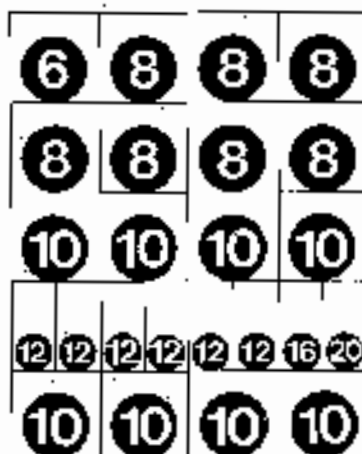

MODEL 5524

Capacity as shown: 250 units

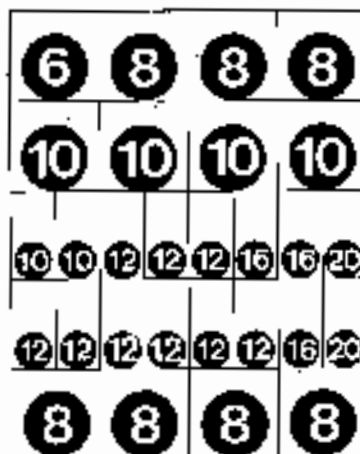

MODEL 5528

Capacity as shown: 318 units

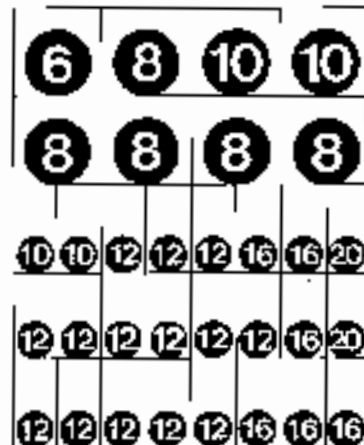

MODEL 5532

Capacity as shown: 390 units



MODEL 5536

Capacity as shown: 448 units



MODEL 5540

Capacity as shown: 520 units

### PRODUCT SIZE CAPABILITY

SHELVES	HEIGHT	WIDTH of Snack Shelves Only	WIDTH of Candy Shelves Only	DEPTH OF Snack Spirals Only Choice:	DEPTH OF Candy Spirals Only Choice:
Top	7-3/4"	2 1/4" to 5 1/4"	1" to 2 1/4"		
Second	7-1/4"	2 1/4" to 5 1/4"	1" to 2 1/4"		10 - Item Spiral 1-5/16"
Third	6-5/8"	2 1/4" to 5 1/4"	1" to 2 1/4"	6 - Item Spiral 2-1/16"	12 - Item Spiral 1-1/16"
Fourth	6"	2 1/4" to 5 1/4"	1" to 2 1/4"	8 - Item Spiral 1-11/16"	8 - Item Spiral 3/4"
Fifth	6-5/8"	2 1/4" to 5 1/4"	1" to 2 1/4"	10 - Item Spiral 1-5/16"	20 - Item Spiral 1/2"

Eight selection shelves for candy and other narrow items fit on all five positions.

Spiral of one item capacity can be freely interchanged with any other of the same diameter.

Boxed items may need slightly larger clearances to vend properly.

Movable spacers available to adjust widths to ranges shown in each selection.

Gum and Mini Capacity: It is difficult to determine the true capacity due to variations of product size. The average capacity for the Gum & Mint stack is 140 items.

The Snackshop 5000 is assembled and packed so that a minimum amount of time is necessary for preparation to install it on location. The following steps are recommended to insure correct unpacking.

1. **Shipping Damage:** Thoroughly inspect the exterior of the carton for damage which may have occurred during shipment. Report any damage to delivering carrier and follow their instructions.
2. Remove staples from lower edge and those at top of carton, and slit carton vertically at the taped corner. Open and remove carton. Remove the remainder of the packing material. On machines shipped with lock in place, the keys are stapled to the carton base.
3. Remove leg leveling bolts from underside of crate base using a 1 3/8" socket wrench. Remove crate base and re-install leveling bolts into legs of machine.

**NOTE:** Because the weight concentration is toward the back of the cabinet, trucking and lifting should be done from the back. **CAUTION** should be taken when trucking from side.

4. On machines with lock in place, unlock and lift handle to open door. When no lock is furnished, remove lock handle retainer clip and lift handle. Swing door to its full open position.
5. Remove all packing tape and paper from various areas of machine.
6. **Warranty:** The warranty card is attached to the cover of this manual. It must be filled out in full and mailed at once to insure coverage.

## installation

1. **LEVELING THE MACHINE** or location is important for the proper function of the machine. The four leveling screws in the legs are the means of leveling the machine. After positioning the machine, level machine in front, in rear and right to left directions. After leveling, turn front right (lock side) leveling screw in about one-half turn to drop this corner slightly to make the door easier to close and lock.

2. **THE MAIN POWER CORD** extends out the back left rear of cabinet and is taped. The cord has a 3 pin grounded plug attached. Untape and plug cord into a properly grounded 115V 60 HZ outlet only.

In order to comply with electrical safety regulations and Underwriters Laboratories requirements, all electrical equipment must be properly polarized and grounded. The Snackshop 5000 is wired so that it is properly polarized in accordance with the electrical code. If the wall outlet is wired and grounded properly, then the vendor will connect properly.

Shown in View A & B are two properly grounded and polarized wall outlets. One is a three wire grounding type wall outlet (see View A) and one is a two wire wall outlet (see View B) with an adapter in place. To make a polarity check use a 115 volt neon test lamp as shown or a volt ohm meter. The hot side of the circuit should always be counter-clockwise from the ground terminal (which should be at the bottom).

Should the polarity at the wall outlet show any way other than that shown above, the outlet should be rewired.

3. **LOADING SNACK SHELVES:** Open door to full open position, push down on white plastic lock lever (Figure 1) on right side panel by shelf to unlock shelf, holding lever down. Grasp the shelf, under both front corners (see Figure 1), lift front shelf slightly and pull forward until shelf

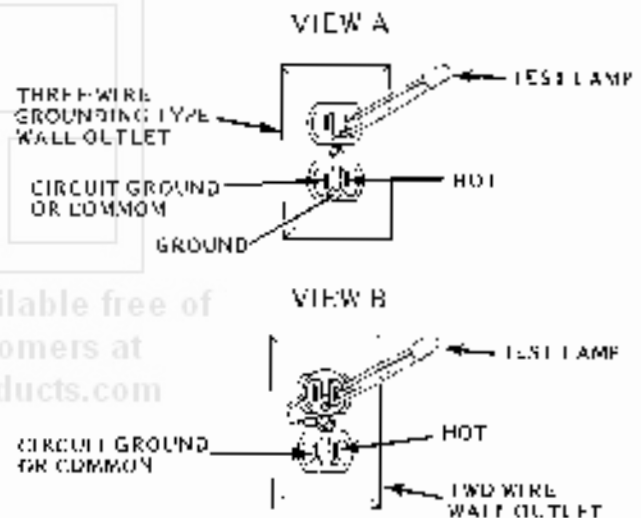

reaches its stop. The shelves tilt down (do not drop) to make loading easier. Only one product shelf should be in the loading position at a time. When returning a shelf, be sure the shelf is in its full home or vend position. Begin loading with the top shelf. Move it to the loading position. The height spacing for trays is greatest in this shelf and the tallest bagged items should be placed there. Soft items, such as pastry, pies, etc., should be placed in the lowest snack shelf, making the drop distance as short as possible.

**IMPORTANT:** Product must not be forced into the spiral spaces but should fit freely. If the product is too tight, use a larger pitch spiral. The bottom of the product should be placed on top of the spiral wire that rests on the shelf surface (see Figure 2). The width of the product must be greater than the diameter of the snack spiral. If it is smaller, the product may fall through when it is in the front ready to vend position.

## installation

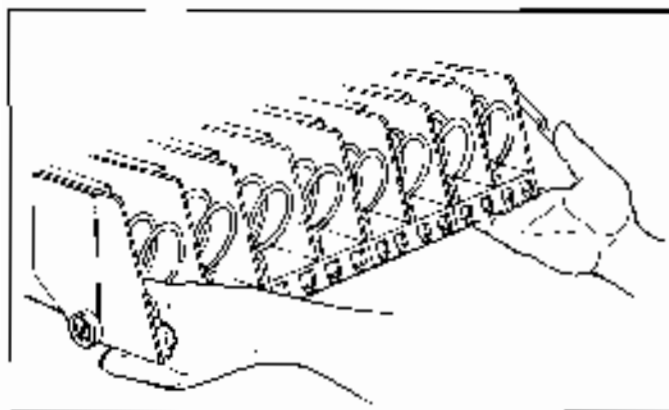

Figure 1. MOVING SHELF TO LOADING POSITION.

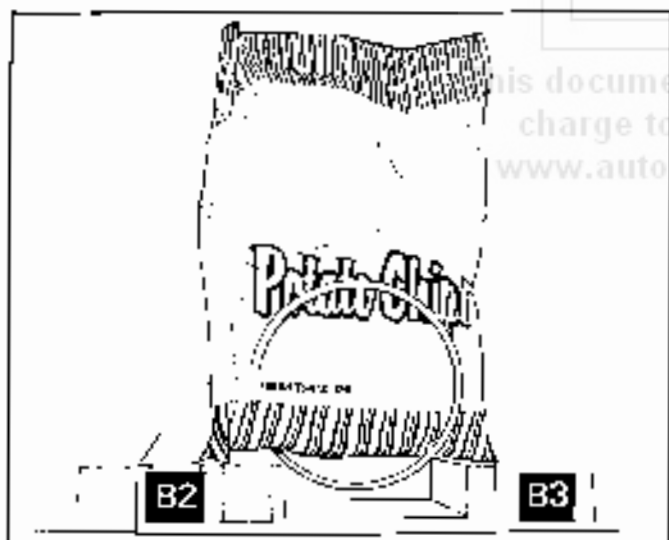
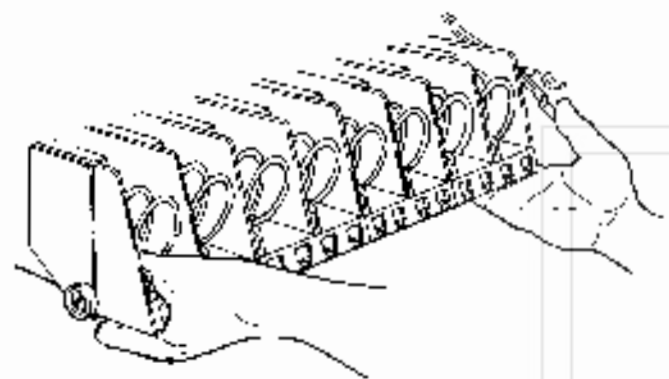

Figure 2. PLACEMENT OF PRODUCT ON MAIN PRODUCT SNACK SHELVES AND FRONT END POSITION OF SPIRAL.

4. REMOVAL OF SPIRAL: To remove the spiral, grasp the spiral near the rear of the shelf and pull forward. To install a spiral, align the hole in the cross strap, at the rear of spiral, with the motor shaft. (See Figure 3). Be sure the front end of the spiral is positioned properly (with the

front end of spiral pointing downward on the left side) (see Figure 2). Align strap between retainer tabs on spiral retainer (see Detail A, Figure 3) attached to motor shaft, push spiral to rear until both tabs snap over strap (see Figure 3). Give a light forward pull on front of spiral to check if it is locked in place.

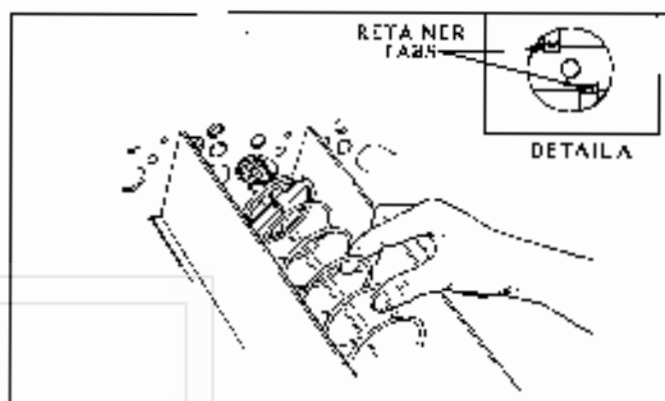

Figure 3. REMOVING AND INSTALLING SPIRAL.

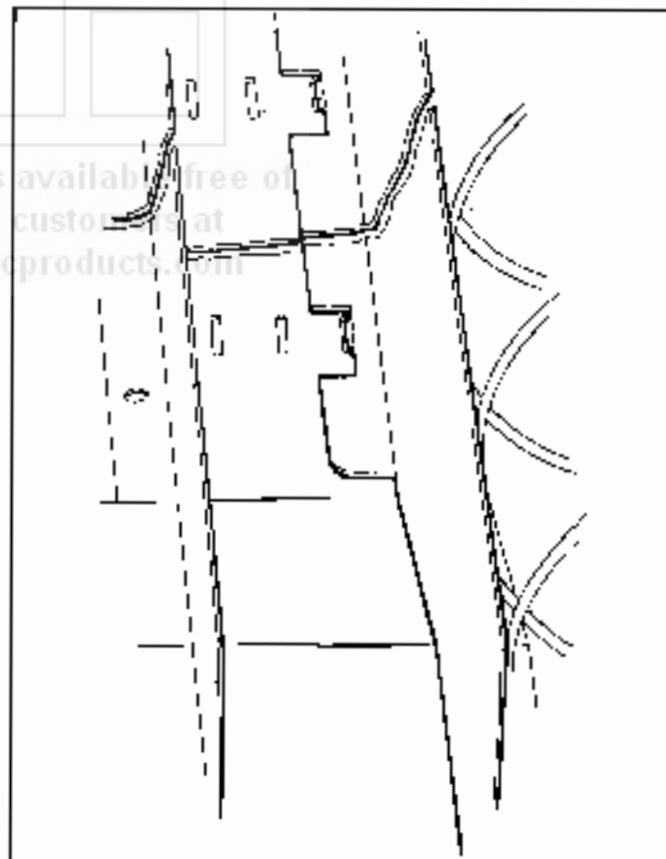

Figure 4. ALIGNMENT OF MOVEABLE PRODUCT SPACERS.

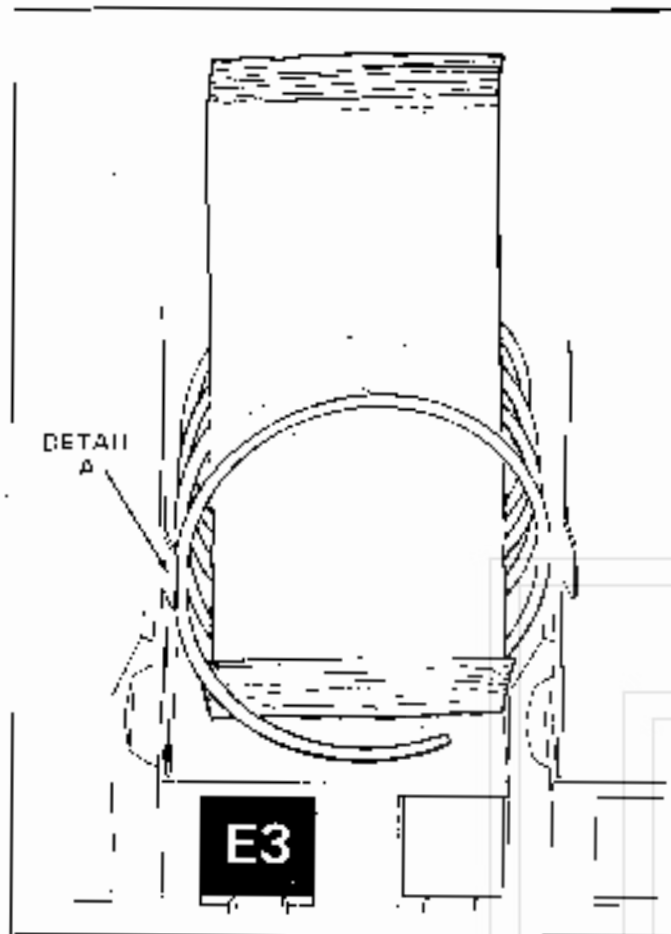

Figure 5. PLACEMENT OF PRODUCT ON MAIN PRODUCT CANDY SHELVES AND FRONT END POSITION OF SPIRAL.

5. **PRODUCT SPACERS—4 SELECTION SHELF:** A product spacer is used to reduce the width of the product area and should be used on any 4-selection snack shelf where the product width is  $4\frac{1}{8}$ " or less. Spacers should fit within  $1/8$ " of the product but should not fit tight against the product. There are three positions in each snack space where these spacers can be placed. To install the spacer, align the lock ears (on the lower edge of the spacer) with one of the three sets of slots (one front and one rear). (See Figure 4). Push the spacer to the rear to allow the ears to enter the slots, then allow the spacer to move forward. Be sure the ears are in the same set of slots, front and rear. (See Figure 4). Continue loading all spirals, adjust width spacers where needed in the top shelf. Return the top shelf to the vend position and following this procedure load the remainder of the large spiral shelves. The shelf divider separating the right (lock side) column from the next column is movable to allow vending of products wider than  $5\frac{1}{8}$ " in the second column. If this is used the right column must be used to vend a narrower product.
6. **LOADING MAIN PRODUCT CANDY SHELVES:** The 8-selection (candy type) shelves are loaded similar to the 4-selection shelves except that the bottom of the product sits on the shelf in front of the spiral wire (see Figure 5) that rests on the shelf. These products must also fit prop-

erly in the spiral space; do not force product into spiral. These spirals are removed and installed the same as the large spiral (see Figure 2), except that the front end position is different (approximately 5 o'clock) (see Figure 5) and the front left side of the spiral must be behind the small tab located on the left side of the product space's side wall (see Figure 5, Detail A).

7. **PRODUCT SPACERS—8 SELECTION SHELF:** The 8-selection shelves are equipped with a product spacer (see Figure 6) that can be pivoted from the right side of each product space. These spacers should be pivoted out to hold the product upright, but not tight against the product. Leave about  $1/8$ " clearance between the spacer and the product.
8. **PRODUCT PUSHER:** The machine contains enough pushers for you to install a pusher on each candy spiral. This plastic part is designed to push the top of the product forward while it is vending, helping it fall from the shelf. It can also be used with products that have the wrapper end flap on the outside of the package. In this case, the pusher prevents these products from hanging on the spiral by spreading the flap. The pusher is installed approximately 210 degrees from the front end of the spiral with the tab extending forward (see Figure 7).

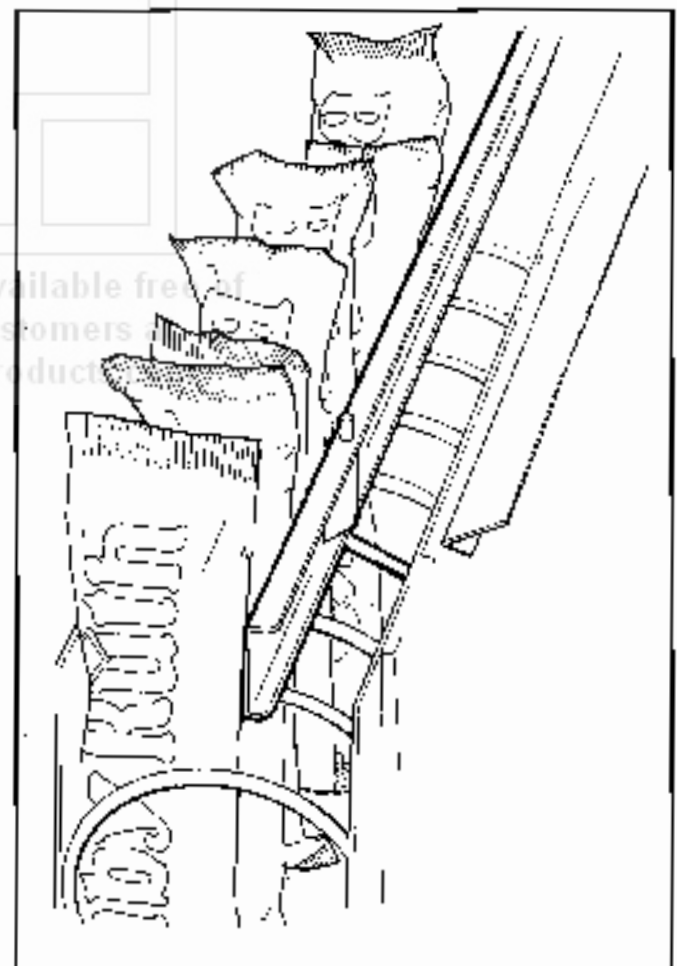

Figure 5. 8 SELECTION SHELF PRODUCT SPACER POSITIONED TO HOLD CANDY UPRIGHT.

## installation

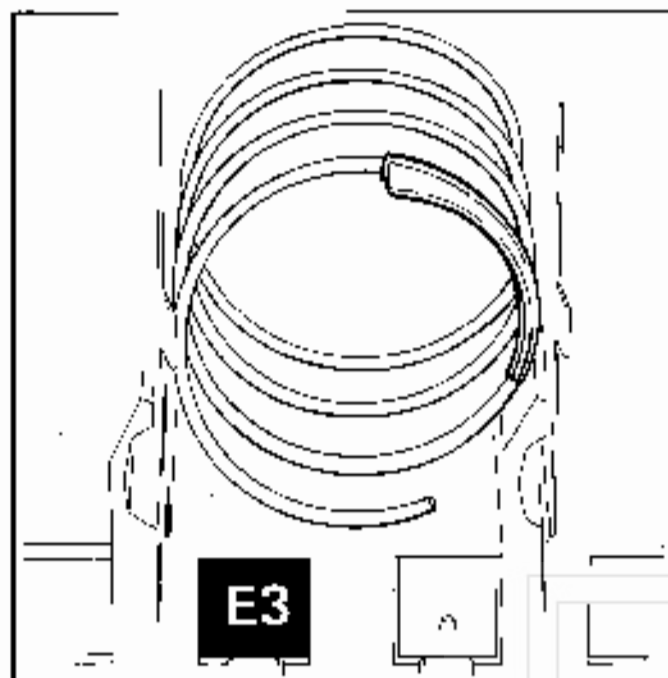

Figure 7. LOCATION OF PRODUCT PUSHER ON SPIRAL.

Locate the pusher in its proper position, hold it against the spiral wire and push the semi-circular part around the spiral wire.

3. BAGGED ITEMS in the 8-size section shelves if not loaded properly could be a problem. The sealed edge of the bag may get under the spiral wire causing the product to hang up after it has been vended. It is recommended that the inner edge of these types of product be folded forward and up (see Figure 8) next to the product before inserting it to the spiral space.
10. CIGARETTE VENDING FROM SNACKSHOP 5000. Cigarettes can be vended from the candy shelves using the (10 capacity) spiral for the soft pack regular, king, 100mm or (20mm packs). The (8 capacity) spiral should be used for (box) packs.
11. LOCK PRODUCT SHELVES. After all the product has been loaded be sure all shelves are returned to their vend position behind the front roller guide.
12. INSTALL PROPER PRICE TABS into price tab holder for each selection in the main product area. (See Figure 9).
13. LOADING GUM & MINT: The Gum and Mint columns and drive mechanism are located on the sliding panel. Pull out the sliding panel. Unlatch the Gum & Mint stack and lower it to the loading position. Two columns have fillers which may be removed to vend long mints. When reinserting these fillers into the stack, be certain the "strips" of the fillers are in the holes of the stack. One column con-

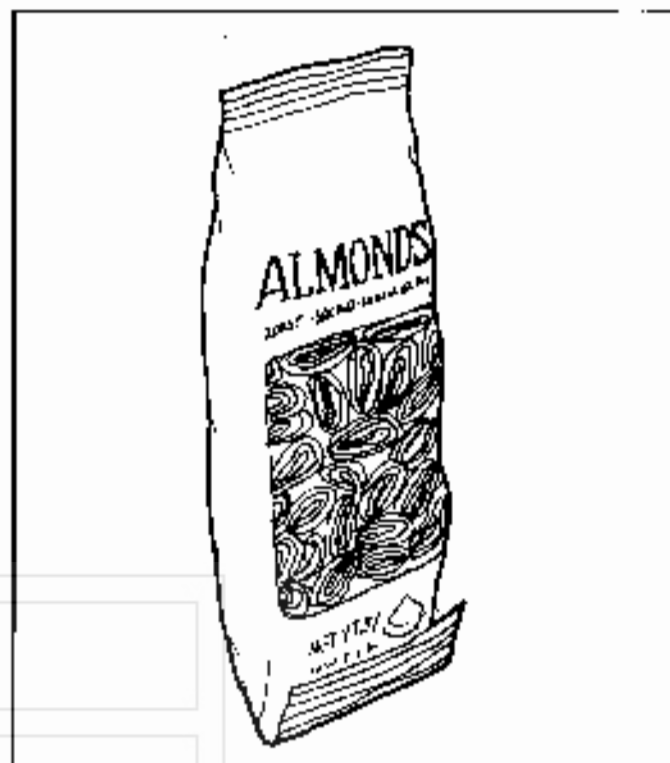

Figure 8. FOLD BAGGED ITEMS BOTTOM EDGE FORWARD AND UP.

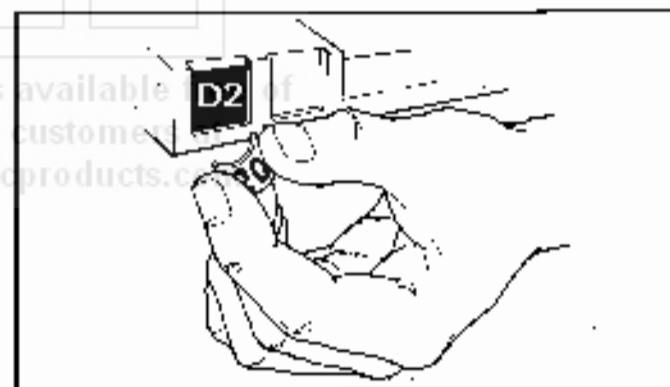

Figure 9. INSTALLING PRICE TABS.

tains a thin mint filler. This filler should be removed to vend gum or regular size mints. Gum & Mint retainers are attached to the base of each column with a wing nut. The retainers should be positioned accordingly with the instruction decal which shows the proper settings. After all the columns have been loaded, return the Gum & Mint stack to its up and locked position. Remove the Gum & Mint display box off the door and fill it with the correct product for all of the selections.



## INTRODUCTION

The Snackshop 500II represents a new concept in vending. There are no pricing switches, vend relays or individual selection switches. All of the machine functions are managed by a Control Board located on the inside of the door. The Control Board operates much like a computer. In addition to controlling normal machine functions the Control Board has a memory and micro processor for the incorporation of an M.I.S. (Management Information System). M.I.S. was designed to give the operator an accurate and up-to-date view of product movement through the machine (product inventories, cash inventories, service time, etc.). Although M.I.S. is an invaluable tool for the operator, it is not necessary for normal machine operation. The following instructions deal with the functioning and set-up operations of the machine with and without the use of M.I.S. Read the instructions from beginning to end to get a complete understanding of all machine functions and the interrelationships of components.

### 1. POWER SUPPLY

The 115V. AC. power cord plugs into the switch and circuit breaker box located below the shelf toward the hinge side. All connections from the transformer, lights, fan (optional) and to the machine connect on the hinge side of this box. All connections are different so you cannot get them plugged wrong. The transformer supplies two output voltages: 28 VAC and 12.6 VAC. These voltages pass through the circuit breakers located above and below the power switch. The green leads from the transformer are 28 VAC and the red leads are 12.6 VAC. The 28 VAC and 12.6 VAC go only to the Control Board. The voltage used on the vend motors and switches is 24 VDC. **DO NOT** test motors with AC and be sure polarity is correct or damage will result. When removing or installing any component be sure the power is off, if the Control Board has to be removed, take special care. **DO NOT** lay the board on a metal surface.

**CAUTION:** Do not short battery lines as an explosion could result.

### 2. CHANGER

The changer is to be mounted on the changer mounting bracket located on the gum and mint sliding panel. Remove the changer hold down screw which has been installed in this bracket for shipment. Hang the changer on the shoulder studs provided. Re-install the hold down screw to lock the changer in place. After securing the changer to the changer mounting bracket, plug the changer into one of the two receptacles located below the gum and mint stack. The changer plug will determine which receptacle should be used. Be sure the changer cord is clear of the coin return lever operation. Load change into the payout tubes and turn the power switch on.

### 3. MODE SWITCH BOX

The mode switch box is located on the door above the changer. It allows for control of the following machine functions: Operate mode, set price mode, check price mode, test vend mode, service mode and set serial number mode (see Figure 10).

**IMPORTANT:** When operating the machine in any mode other than the operate mode, the door must be open. The machine is automatically put in the operate mode whenever the door is closed.

**NOTE:** Before closing the door push the operate button to home any motors which may be out of position.

- A. Operate Mode—Normal machine operation featuring total control of coin mechanism operation and accountability.
- B. Set Price Mode—Used to program each selection with a price and/or product code.
- C. Check Price Mode—Used to check prices and/or product codes of programmed selections.
- D. Test Vend Mode—Allows normal machine operation as in the "operator" mode except management data is recorded separately from data recorded in the operate mode.
- E. Service Mode—Indicates the operational condition of all L.E.D. displays and vend motors.
- F. Set Serial Number Mode—Machine identification number for M.I.S. accountability.

### 4. SELECTION PANEL & CONTROL BOARD

The selection panel (Figure 11) on the Snackshop 500II incorporates the use of a self enclosed membrane switch panel. This eliminates the need for individual switches and wiring. The membrane switch panel is housed in a stainless steel panel with individual buttons protecting the switch face. The stainless steel front also houses the instruction and digital display glass (Figure 12). Included on the instruction glass are three messages for customer instruction when the machine can not complete a vend for an item selected (Figure 12). If this condition occurs, an audible signal is given to the customer and an L.E.D. next to the proper instruction will flash until the customer takes further action.

Removal of the selection panel:

First, turn the power off in the machine. Disconnect all the plugs on the control board. Remove the four shoulder screws (Page 27, Item 23) holding the control board cover. Remove the four nuts (Page 27, Item 24) and the control board. Remove the two board spacer locks (Page 27, Item 15) and the four board spacers (Page 27, Item 26). Next, remove the door coin chute (Page 27, Item 21) and the two nuts above this chute. (**NOTE:** The coin return assembly does not have to be removed.) Replace the selection panel and trim by reversing the above procedure.

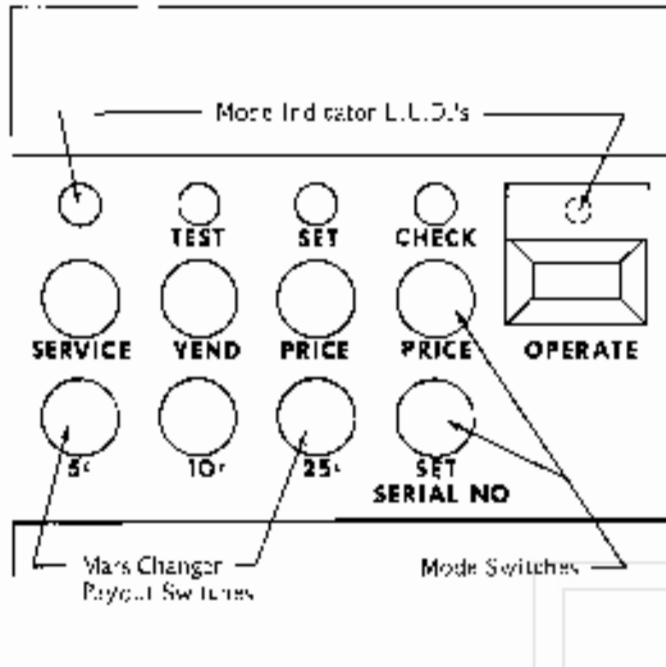

Figure 10. MODE SWITCHES.

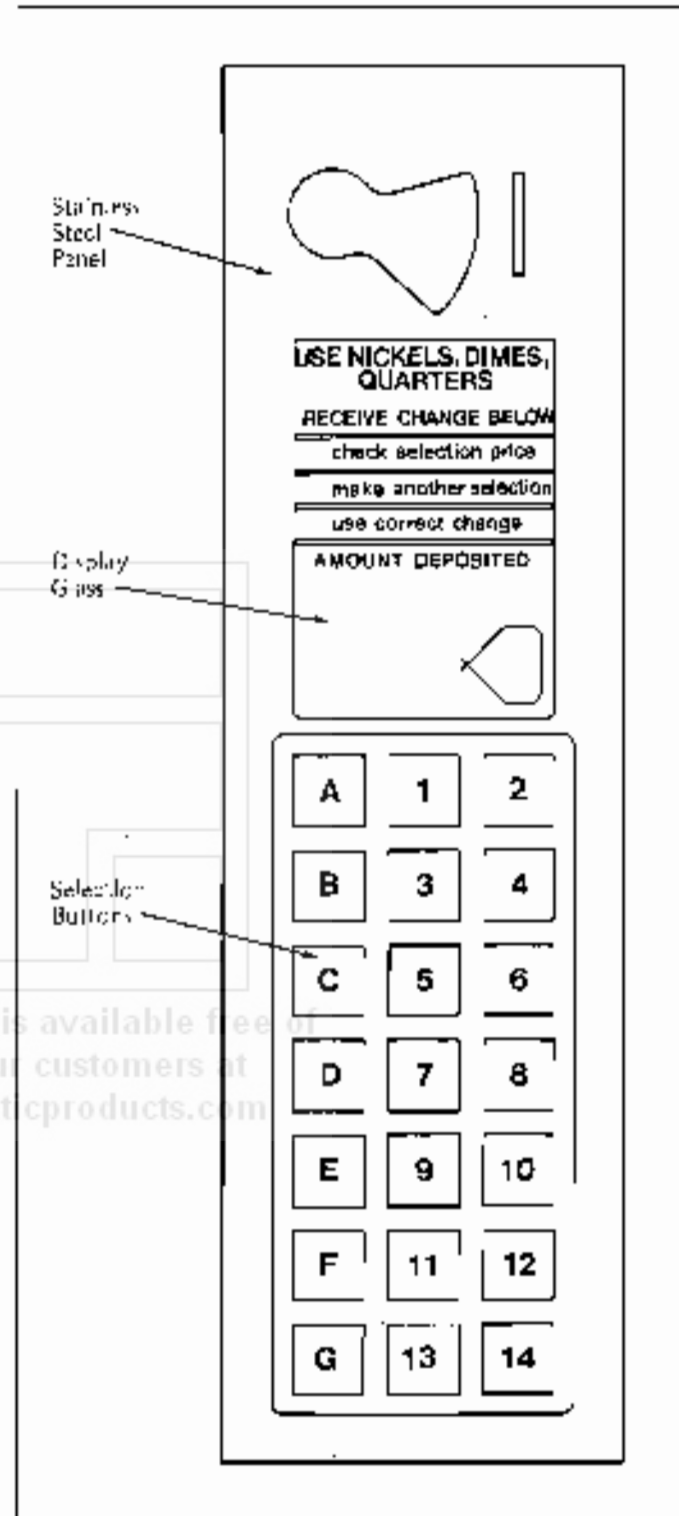

Figure 11. SELECTION PANEL

5. VEND MOTORS

The Snackshop 500II incorporates the use of a high RPM DC Motor. The new DC Motor has an 55% greater starting torque over the Snackshop 400/500 AC Motor, yet weighs only 40% of the AC Motor's weight. Due to the new design, the vend motor may no longer be hoisted by hand, **DO NOT TRY TO TURN THE SPIRALS BY HAND. DAMAGE TO THE MOTOR WILL RESULT.** Any necessary hoisting will be done by the machine. It is also important to check polarity before applying current to the motor. Two diodes and a capacitor are used to prevent circuit feedback and may have to be checked when trouble shooting motor problems.

PRICE SETTING WITHOUT USING M.I.S.

Pricing is done through the selection panel in conjunction with the mode switch box.

- A. Press the "set price" button on the mode switch box (Figure 10). The L.E.D. above the set price button will light and the product code display located on the selection panel will be explained later. Any selection programmed at this reading will be removed from the operating program. This would be used when shelves are moved or the number of selections changed to remove those selections not present in the machine from the program.
- B. Press button 1 on the selection panel and the display will show "00.00" (Figure 14). This is the price display and can be incremented up by pressing button 11 and down by crossing button 12. Increments are 5¢. **CAUTION:** Any selection programmed at "00.00" will free vend.

- C. With the selling price displayed, press first the letter, then the number for each selection to be sold at that price. Increment to your next price and enter those selections. Repeat until all selections have been programmed with their proper price and product code.

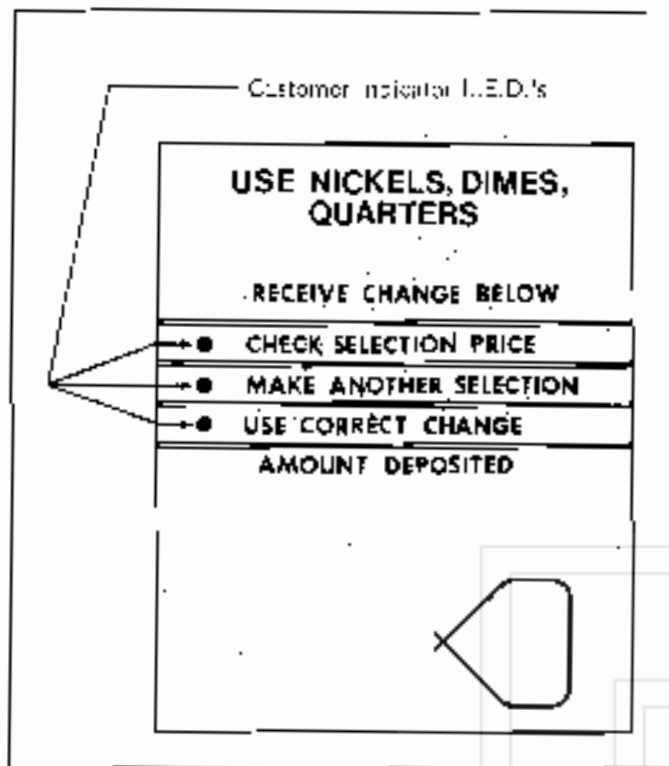

Figure 12. INSTRUCTION AND DIGITAL DISPLAY GLASS.

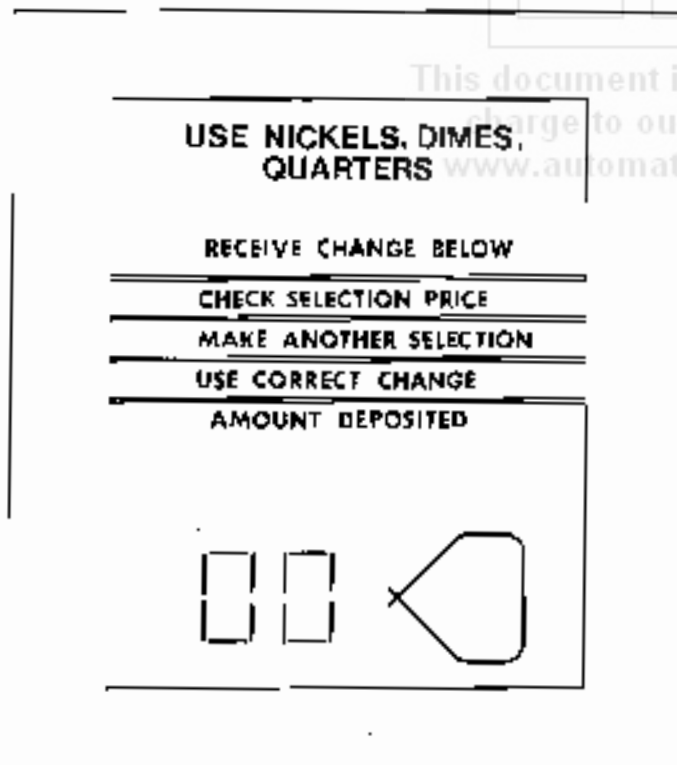

Figure 13.

6. PRICE CHECKING WITHOUT USING M.I.S.

After all prices have been programmed, they should be checked to verify that each selection has been programmed correctly.

- A. Press the "check price" button on the mode switch box (Figure 10). The I.E.D. above the check price button will light and the selection panel display will be blank.
- B. Press the letter and then the number for the first selection to be checked. The price display will show the price that selection is programmed for (Figure 13). Check the displayed price against the price tag on the shelf for that selection.
- C. Continue to check prices until all selections have been checked. Follow "Price Setting Without Using M.I.S." instructions to correct any errors found.

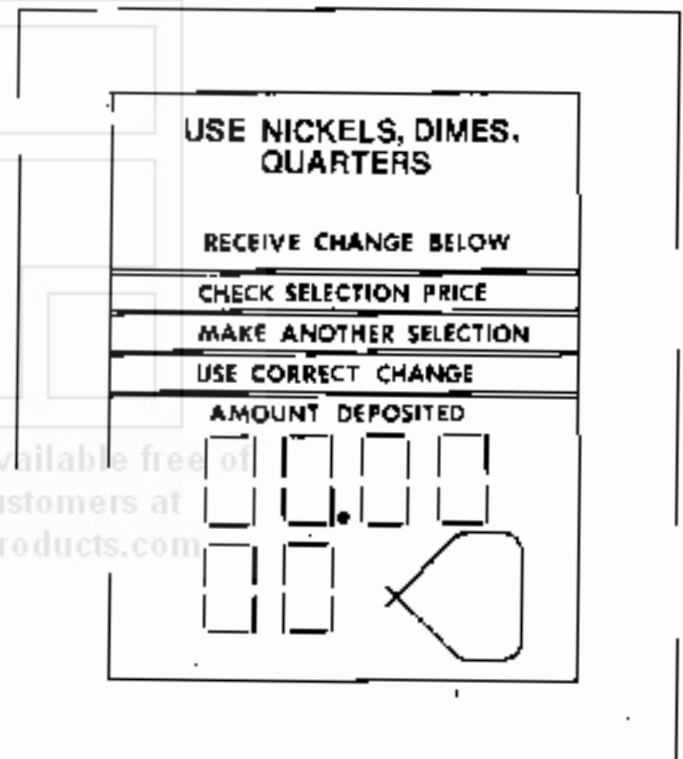

Figure 14.

7. MANAGEMENT INFORMATION SYSTEM (M.I.S.)

The Snackshop 5000 is equipped with the data collecting capabilities and the hardware to function as part of the Management Information System. When you are using the M.I.S., the price setting and price checking require the use of a product code. This gives the operator the versatility to use the product codes in any way to best fit his operation.

A product code is a number (00 through 64), used to identify a specific product or group of products. The product code need only be used when M.I.S. is being used. The product code gives the operator total control of individual product sales or product group sales.

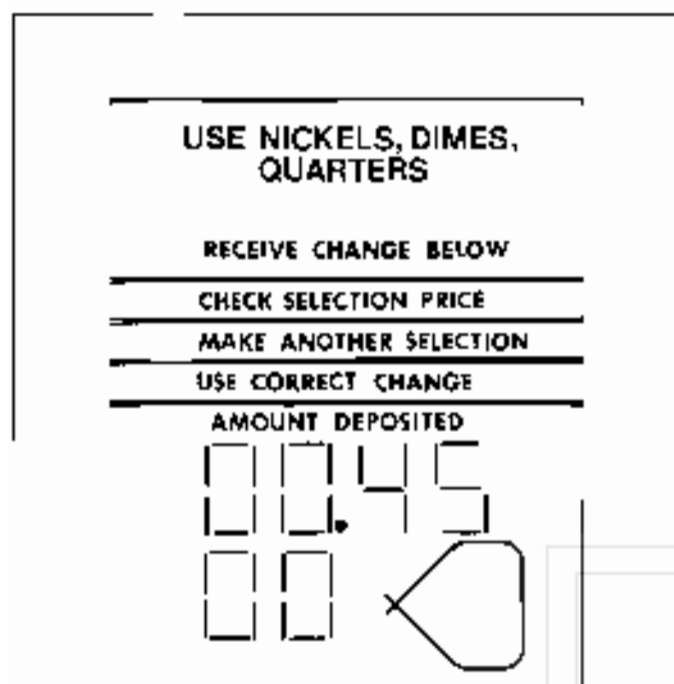

Figure 15. SHOWING A SELECTION PROGRAMMED FOR 45¢

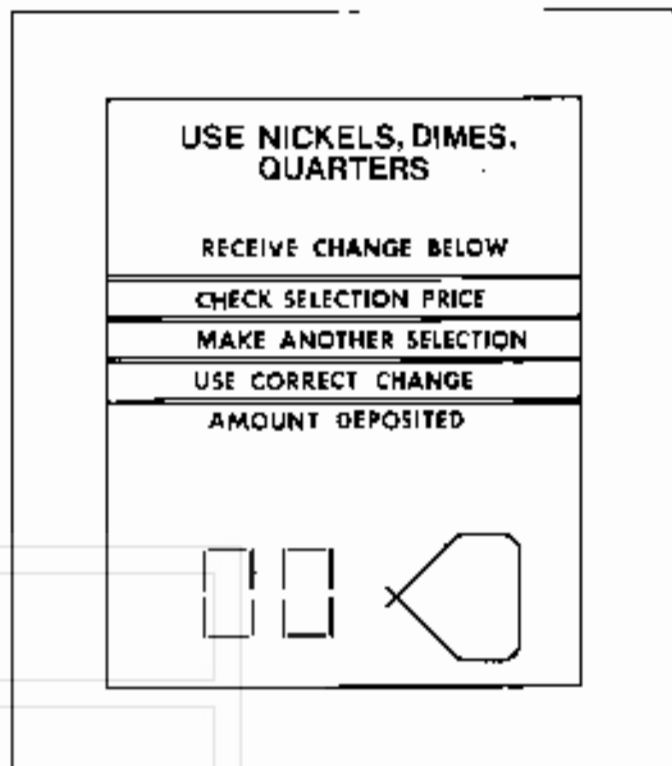

Figure 16.

The M.I.S. records by product code, the number of vends and total dollar amount vended for each product code programmed. This gives the operator the versatility to program a product code for each selection in the machine or one product code for all selections within the machine.

Increment in your next price and/or product code and enter those selections. Repeat until all selections have been programmed with their proper price and product code.

## B. PRICE SETTING USING M.I.S. AND PRODUCT CODE

Pricing is done through the selection panel in conjunction with the mode switch box.

- A. Press the "set price" button on the mode switch box (Figure 10). The L.E.D. above the set price button will light and the display located on the selection panel will show "00" (Figure 16). This two digit display is the product code and can be incremented up by pressing button 13 and down by pressing button 14. Increments are one. Any selection programmed at this reading will be removed from the operating program. This would be used when shelves are moved or the number of selections changed to remove those selections not present in the machine from the program.
- B. Press button 11 on the selection panel and the display will show "00.00" (Figure 17). This is the price display and can be incremented up by pressing button 11 and down by pressing button 12. Increments are 5¢. CAUTION: Any selection programmed at "00.00" will free vend.
- C. With the product code and selling price displayed, press first the letter, then the number for each selection to be sold at that price and product code.

## 9. PRICE CHECK USING M.I.S.

After all prices and/or product codes have been programmed, they should be checked to insure that each selection has been programmed correctly.

- A. Press the "check price" button on the mode switch box (Figure 10). The L.E.D. above the check price button will light and the selection panel display will be blank.
- B. Press the letter and then the number for the first selection to be checked. The display will show the price and product code that selection is programmed for (Figure 15). Check the displayed price against the price tag on the shelf for that selection.
- C. Continue to check prices and product codes until all selections have been checked. Follow "Price Setting Using M.I.S." instructions to correct any errors found.

## 10. CASH ACCOUNTABILITY DISPLAY

A running total of dollars vended by the machine may be displayed on the selection panel display without the use of the M.I.S. This total may not be changed by anyone and represents an accurate cash accountability meter.

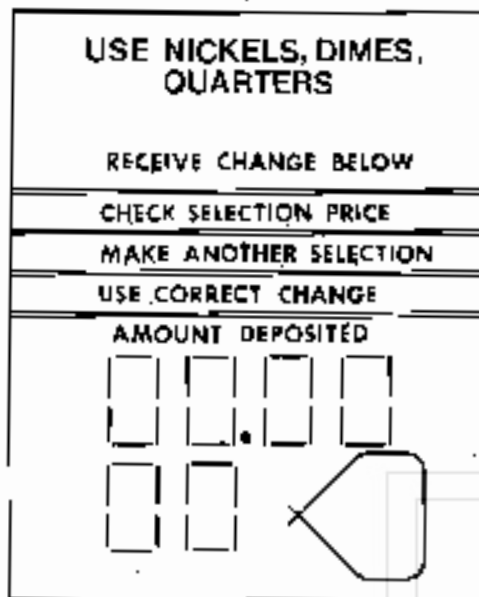

Figure 17.

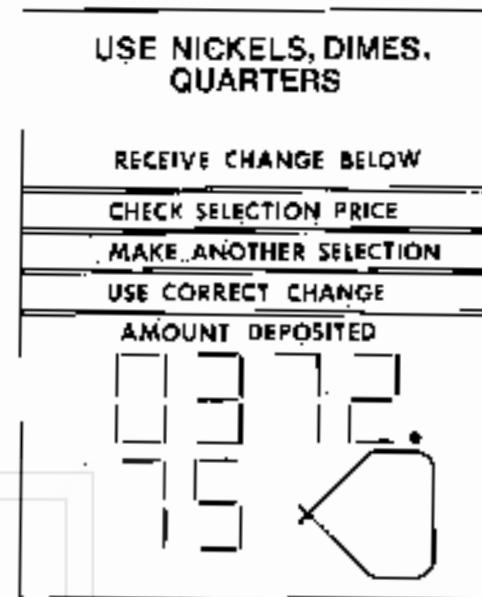

Figure 18. SHOWING \$3.72

- A. Press the "check price" button on the mode switch box (Figure 17). The L.E.D. above the check price button will light.
- B. Press button #4 on the selection panel and the total dollars vendored by the machine will be displayed (Figure 18).

#### 11. TEST VEND MODE OPERATION

The test vend mode was incorporated in the Snackshop 5000 to allow machine servicing and testing without affecting the management data or cash accountability of customer vends and customer dollars received. When M.I.S. is not used, the test vend mode prevents service and test vends from being included in the cash accountability readout. When M.I.S. is being used, the test vend mode records the number of vends and dollar amounts received, in a separate category from that same information which is recorded in the operate mode. This gives the operator total control over all product amounts sold and dollar amounts within the machine.

- A. Press the "test vend" button on the mode switch box (Figure 10). The L.E.D. above the test vend button will light and the display located on the selection panel will be blank. The machine is now ready to operate exactly under the same conditions as in the operate mode, so you will have to use money for the testing. After all servicing and testing has been made return the machine to the operate mode. The machine is now ready for normal customer usage.

#### 12. MACHINE IDENTIFICATION NUMBER FOR USE WITH M.I.S.

When using the M.I.S. each machine must have an identification number.

- A. Remove the hole plug located on the mode switch box above the words "set serial no.". The set serial number switch will be located beneath the hole plug.
- B. Press the set serial number mode switch. The set serial number (if there is one) will be displayed on the selection panel.
- C. Enter the new number by pressing the panel number buttons; Button #10 equals 0 (Figure 19).

#### 13. SERVICE DIAGNOSTIC DISPLAY

Incorporated in the Snackshop 5000 series machine is an automatic circuit check. When the machine is engaged in the "operate" mode a scan is made to check the operating condition of all selection motors. Any non-functional motors are recorded and can be displayed for trouble shooting corrections.

- A. Press the "service" button located on the mode switch box (Figure 10). The L.E.D. above the service mode button will light and those out of panel L.E.D.'s will all light (Figure 20). This tells the service person if all L.E.D.'s are in operating condition and that the Control Board is operating.

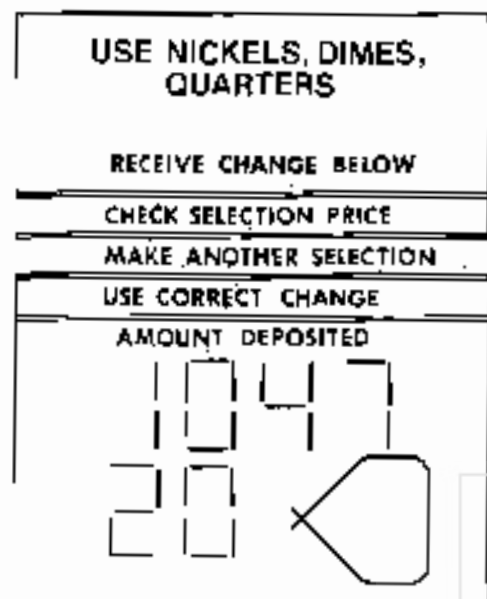

Figure 19. SHOWING A SERIAL NUMBER OF 104720

14. USE OF V.I.S.

The Snackshop 5000, as stated earlier, is equipped to gather information for an V.I.S. Either the Mars or Coinco data retrieval unit can be used. Refer to Figure 22 for data retrieval hook up location. The following data is given out by the Snackshop 5000.

- A. Serial number for machine identification.
- B. Total dollars vendored for all products sold.
- C. Total cash to the cash box (Mars change only).
- D. Total number of interrogations or information readouts.
- E. The last four door openings greater than five minutes apart.
- F. Total test vendored cash.\*
- G. Total test vendored cash in the cash box (Mars change only).\*
- H. Total number of test vendes.\*
- I. Total number of customer vendes per product code.\*\*
- J. Total vendes per product code.\*\*

\*Test vendes and test vendored cash refers to vendes made and cash accepted by the machine when it is in the test vend mode. This allows the route person to make test vendes without affecting the accountability of customer vendes and cash.

- B. Press button 14 on the selection panel, if any of the motors are not functioning (jammed, bad switch, bad harness, etc.) the first non-functioning motor in the series will be displayed on the selection panel display (Figure 21).
- C. If a non-functioning motor exists, record the selection on paper and repeat step B. Continue this procedure until all non-functioning selections have been displayed, recorded and the selection panel display reads all 8's (Figure 20).
- D. If all motors are operational the selection panel display will read all 8's.
- E. Inspect and repair the selections recorded from the service diagnostic display.
- F. After servicing the non-functioning selections return all shelves to a vend position and press the "operate" button located on the route switch box. A slight delay will occur before the operate L.E.D. will light. This delay is the machine making the automatic circuit scan. At the time the scan is taking place any motors not in the start position automatically are torqued. DO NOT TRY TO TURN THE SPIRALS BY HAND. DAMAGE TO THE MOTOR WILL RESULT.
- G. To insure that all serviced selections are operational, repeat steps A and B.

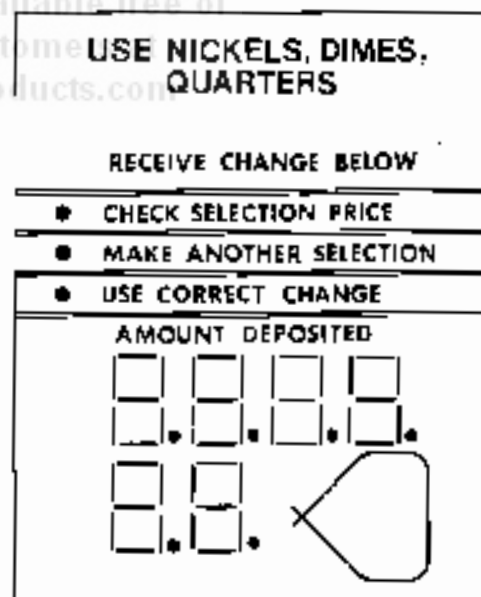

Figure 20.

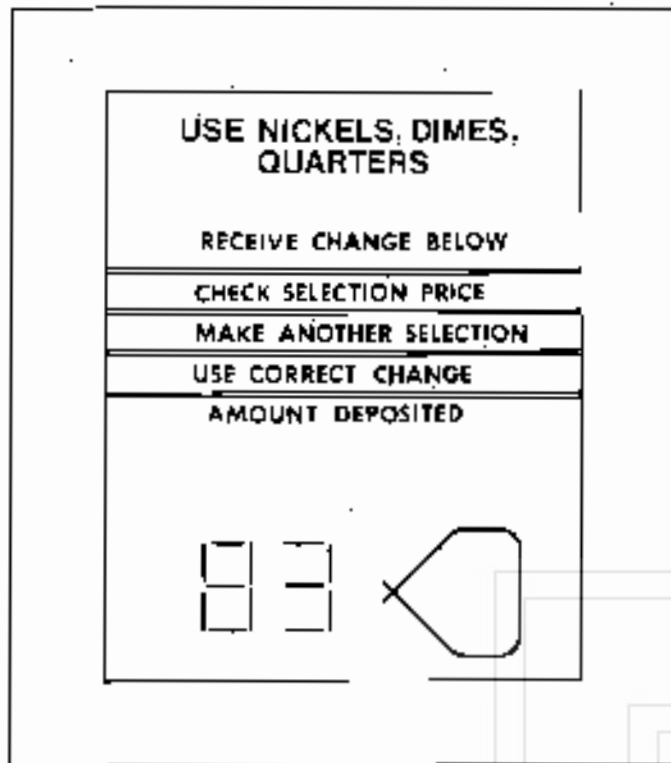

Figure 21. SHOWING SELECTION B3 NOT OPERATING

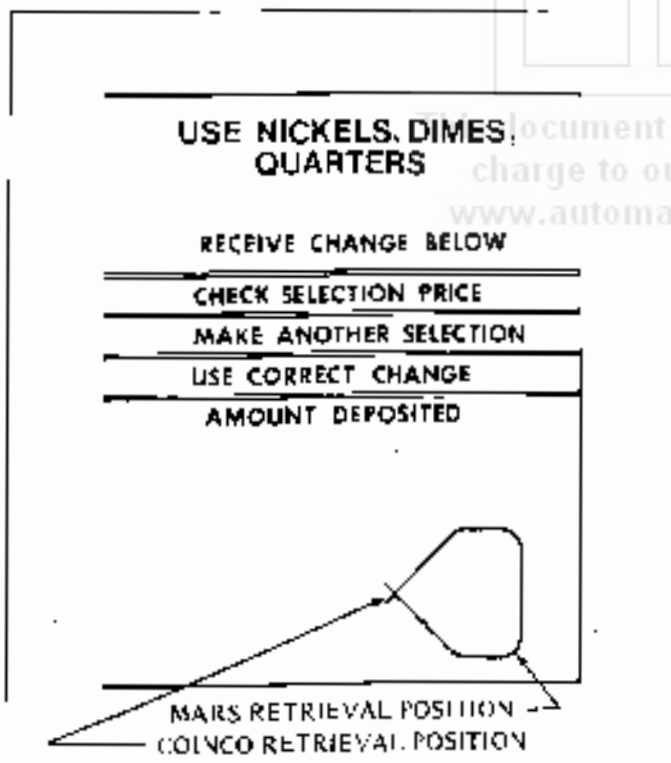

Figure 22

\*\*Customer vends refer to normal customer usage when the machine is in the operons mode.

The interrogator or data probe is a hand held device used to withdraw the information recorded by the M.I.S. for analysis by a computer at the office. Two devices are available: One device withdraws the information through a magnetic coil while the other uses light sensors. The Snackshop 5000 is equipped to handle either device.

15. LIGHTING SYSTEM:

There is only one fluorescent lamp in the Snackshop 5000. The lamp is located in the top of the door, and lights the main product area and the product sign. The starter is located on the hinge side of the lamp. The ballast in the circuit is located on a bracket on the inner pivot side of the cabinet.

16. MAIN PRODUCT SHELVES:

There are five main product shelves per machine. Each containing either four or eight selections. Each selection has its own motor and switch mounted to the back of the shelf. Every shelf has its own harness and plug for connecting to the remainder of the circuit through the cabinet receptacle, located in the rear center of the cabinet. The motors and switches are the same on either type shelf. It is now possible in the Snackshop 5000 to exchange a four selection shelf with an eight selection shelf or vice versa. NOTE: When exchanging the shelves, you will not need any parts, but you will have to reprogram the machines for prices and selections.

REMOVAL OF PRODUCT SHELF:

- A. Lift up and push the lock lever toward the back of cabinet. See figure .
- B. Pull the shelf to its loading position.
- C. Grasp shelf in front and rear center. Lift front of shelf up above horizontal and pull shelf forward while tilting.
- D. To install shelf, reverse above procedure.

7. DELIVERY BIN:

This is located below the display window on the door and is mechanically operated. The linkage on the outside ones of the delivery bin may require occasional lubrication. Should the door become difficult to operate, place a small amount of grease on the arm tracks.

REMOVAL OF DELIVERY BIN:

- A. Remove the screws from the underside of the delivery bin. These screws fasten into the inner door frame and remove the two screws and brackets at the top of the delivery bin.
- B. Grasp delivery bin on both sides and lift up and pull back. Should bin be tight, rock it by lifting on one end, then the other.

REPLACEMENT OF DELIVERY BIN:

- A. Locate lip on front edge of delivery bin over lower edge of opening in door and behind trim. Press down along lip to make sure it is fully engaged between door and trim.

## components

- B. Install the four screws and two brackets, to secure coin to door.

### 18. COIN RETURN

The coin return lever located on the door and the coin return linkage located above the changer, scavenges the coin rejector. Actuation of the coin return lever will clear the rejector of any damaged coins and will also cancel all credit on the changer, returning that amount to the customer.

### 19. COIN ACCEPTANCE:

A coin or coins (¼, 10¢ or 25¢ coin) being deposited pass thru the rejector and into their respective coin paths in the changer establishing the credit. The coins then enter either the self-lined change tubes on the changer or the cash box. Actuation of the coin return lever prior to making a selection will cancel all credit on the changer and will return the amount of deposit back to the customer.

### 20. GUM AND MINT MECHANISM:

The Gum and Mint mechanism is located on the sliding panel. It consists of the Gum and Mint stack, which contains four individual columns. The motor mounting bracket under the Gum and Mint stack contains the four (4) individual vend motors, one for each column. Each motor has a switch mounted to it and a clutch assembly.

#### OPERATION:

When a Gum and Mint selector button is pressed the selection switch will energize the respective motor for that selection. Once the motor has started for a vend, it will complete a cycle as long as the Gum and Mint empty switch is being made. In the event there is only one product left in a column the Gum and Mint empty switch will not be made allowing to light and beep the L.E.D. display (make another selection) on the door.

**NOTE:** All ejectors should be in the inward position.

Should a product jam in the Gum and Mint mechanism the clutch assembly is designed to allow the motor to clutch past and return it to its standby position keeping the vendor operative even though a Gum and Mint selection is jammed. Once a jam occurs in the Gum and Mint unit, it will be necessary to re clutch the Gum and Mint ejector to put it back in cycle. To do this clear the jammed product, set up a credit and press the selector button for the column where the jam occurred, then when the ejector moves to the inward position or standby position, hold the ejector by hand and allow the motor to re clutch. Test cycle several times to assure proper operation.

### 21. REMOVING GUM AND MINT MOTORS AND/OR EJECTORS:

The Gum and Mint motors are mounted to a motor mounting bracket under the Gum and Mint stack. To replace a motor or an ejector, remove the Gum and Mint deflector (Page 22, Item 10). Unlatch and lower the Gum and Mint stack. Remove the two motor mounting bracket screws (Page 22, Item 12 and 4). This will now enable you to pivot the motor mount down on the shoulder screws (Page 22, Item 9) and replace an ejector. To replace a motor, remove the two screws (Page 22, Item 11) that hold the motor to the motor mount and unplug the harness. To reinstall a motor or an ejector reverse the removal procedure.

### 22. GUM AND MINT EMPTY SWITCHES:

Behind the Gum and Mint stack, mounted to the sliding panel is a series of four switches. When a Gum and Mint selection button is pressed, these switches either allow the selection to be vendod (if the column has product) or light and beep the L.E.D. lamp on the door (Make another selection) if that column is empty.

### 23. REMOVAL OF SLIDING PANEL:

The entire sliding panel can be removed from the machine by using the following procedure:

- A. Pull panel to its full position.
- B. Disconnect (6 Pin) plug to the left of the G&M stack.
- C. Remove the receptacle mounting bracket and lay down the harness in the machine.
- D. Remove panel stop bracket located on upper side of roller channel assembly. This bracket is located about 6" from the front edge of cabinet at the top.
- E. Grasp the panel to support its weight and pull forward and lift upward. Be careful that the roller channel does not fall off panel.

#### REPLACEMENT OF SLIDING PANEL:

- A. Engage lower edge of panel in lower track while still supporting panel. Be sure that nylon guide rivets are in place at back of panel (2 rivets) and front of guide track (3 rivets).
- B. Guide roller channel onto upper track and lift and push panel and channel into cabinet.
- C. Reinstall stop bracket. Bracket must be installed in back of channel in top of cabinet, as this bracket is what stops the sliding panel in its inward position.
- D. Plug in the 6 pin plug from the cabinet harness.
- E. Replace the receptacle mounting bracket and the harness to the sliding panel.
- F. Push panel back into cabinet.

## cleaning

The Showcase 5000 will do the best merchandising job for you if it is kept clean. The display window can be cleaned with any good glass cleaner. The exterior and interior surfaces should be cleaned with warm water and mild detergent. Rinse thoroughly and dry all surfaces.

#### CAUTION:

Do not use any cleaners containing silicon as this could cause electrical failures.

The main product shelves can be best cleaned with the spirals and product spacers removed. Refer to page 4 for removal of spirals and page 5 for removal of the product spacer. There are openings in each end of the delivery bin at the back for cleaning out dirt.

Clean the acceptor on the changer frequently as accumulated dirt in this area can cause coins to hang or not be accepted. Follow recommended cleaning procedures as described by the manufacturer.



## 1. VENTILATING FAN: (Kit #750102)

The Ventilating fan operates on 115 volts and keeps a steady flow of fresh air moving through the vendor cabinet. All the vendors are wired with a plug for the fan on the left side of the interlock box. Installation instructions are sent with each kit.

## 2. UNIFICATION KITS:

Unification kits are available to make the vendor compatible with other manufacturers.

## 3. GUM-AND-MINT:

Gum-and-Mint units are available as an option with Snack-shop 5000 vendors.

For information pertaining to loading or servicing gum-and-mint unit, refer to this service manual for loading instructions and for service instructions.

## 4. SOUP DISPENSER: (Kit 750083-0)

A canned soup dispenser is available as an option for use in the five section snack shelves. The dispenser is easy to install and holds up to nine cans in the unit.

# troubleshooting

TROUBLE	CAUSE	REMEDY
Motor runs (2 1/2 turns).	<ol style="list-style-type: none"> <li>1. Capacitor discharging current.</li> <li>2. Defective motor or control board.</li> </ol>	<ol style="list-style-type: none"> <li>1. Resolder capacitor or replace motor.</li> <li>2. Replace motor or control board.</li> </ol>
Spinals turn continuously.	<ol style="list-style-type: none"> <li>1. Defective control board.</li> </ol>	<ol style="list-style-type: none"> <li>1. Replace board.</li> </ol>
Motors run on same number throughout machine A1, B1, C1, D1, E1, F1.	<ol style="list-style-type: none"> <li>1. One of the motor wires is shorting out.</li> </ol>	<ol style="list-style-type: none"> <li>1. Check each individual motor for loose or pinched wire and replace it.</li> </ol>
Cannot set prices in machine.	<ol style="list-style-type: none"> <li>1. Defective selection switch.</li> <li>3. Defective control board.</li> </ol>	<ol style="list-style-type: none"> <li>1. Replace selection switch.</li> <li>2. Replace board.</li> </ol>
Push A & A1 turns. Push B & B1 turns.	<ol style="list-style-type: none"> <li>1. Selector switches shorting out.</li> </ol>	<ol style="list-style-type: none"> <li>1. Replace selector switch assembly.</li> </ol>
No L.R.D. Lights on mode box.	<ol style="list-style-type: none"> <li>1. Plug on interlock box is unplugged or on the mode box.</li> <li>2. Defective control board.</li> <li>3. Mode switch has not plugged correctly.</li> </ol>	<ol style="list-style-type: none"> <li>1. Plug in.</li> <li>2. Replace board.</li> <li>3. Check both ends of harness.</li> </ol>
Press the service mode but cannot empty changer.	<ol style="list-style-type: none"> <li>1. Plug on the mode box is not plugged in right.</li> <li>2. Check the 2 lower plugs on the control board.</li> <li>3. Defective changer.</li> </ol>	<ol style="list-style-type: none"> <li>1. Plug in.</li> <li>2. Plug in.</li> <li>3. Replace changer.</li> </ol>
L.R.D. stays on operate mode.	<ol style="list-style-type: none"> <li>1. Mode box defective.</li> </ol>	<ol style="list-style-type: none"> <li>1. Replace box.</li> </ol>
Machine will not accept coins.	<ol style="list-style-type: none"> <li>1. No power to the machine.</li> <li>2. Defective changer.</li> <li>3. The changer will accept only logical amount of money above the vend price.</li> <li>4. Changer should be installed with power off.</li> <li>5. Defective Changer.</li> </ol>	<ol style="list-style-type: none"> <li>1. Check wall outlet.</li> <li>2. Replace changer.</li> <li>3. Check pricing.</li> <li>4. Turn power off—then on.</li> <li>5. Replace Changer.</li> </ol>
G&M section shows "Make another selection"	<ol style="list-style-type: none"> <li>1. Defective G&amp;M empty switch.</li> <li>2. Defective motor.</li> <li>3. Did not go through operate mode.</li> </ol>	<ol style="list-style-type: none"> <li>1. Replace switch or adjust actuator with product.</li> <li>2. Replace motor.</li> <li>3. Push operate mode switch.</li> </ol>

door - outside front

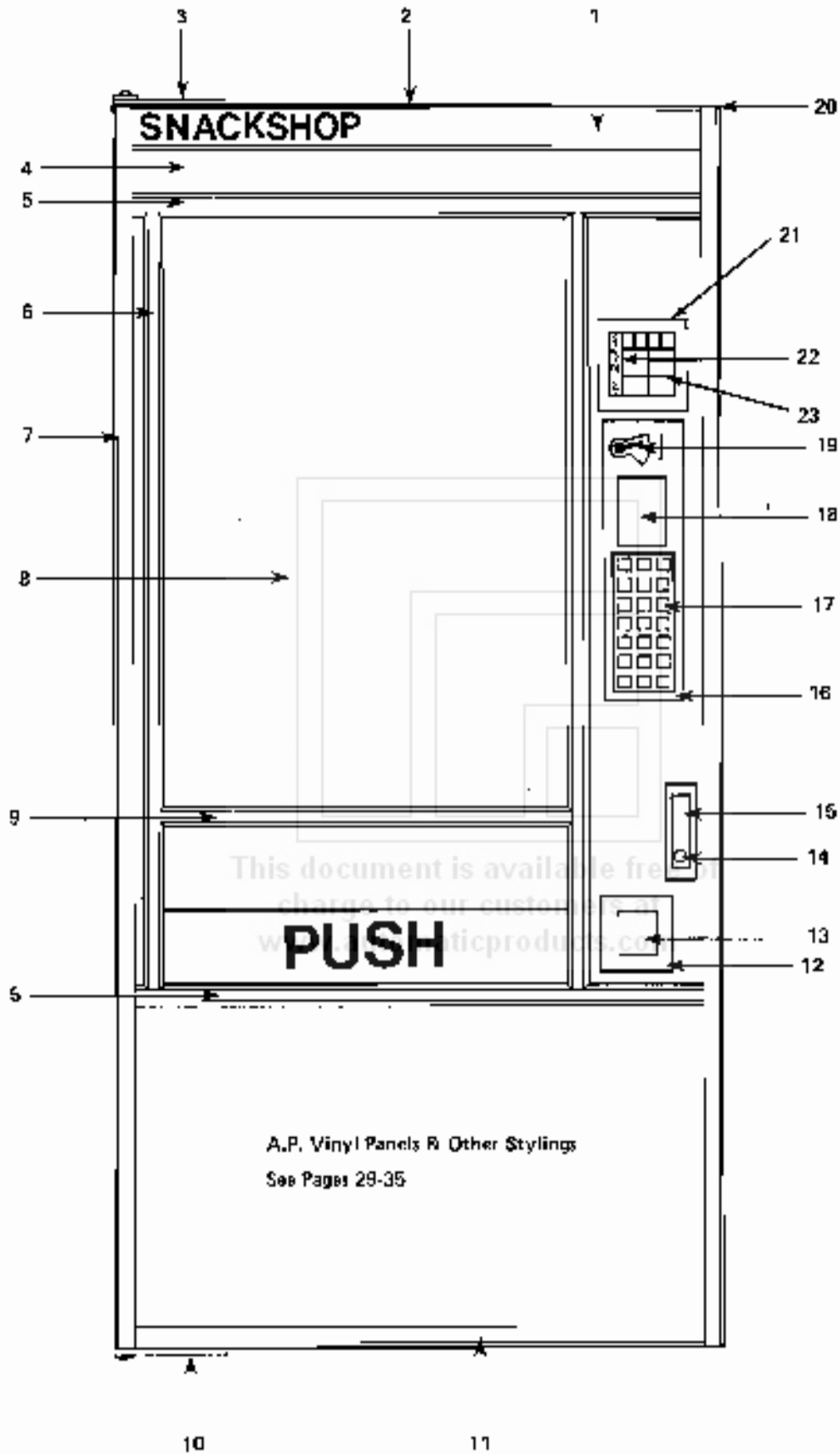

A.P. Vinyl Panels & Other Stylings  
See Pages 29-35

Item No.	Part No.	Description
1	253982-5	Insert, Top Trim, Shackshop.
2	310044-2	Trim, Top. For Use w/Vinyl Insert.
3	641115-1	Top Hinge Assembly.
4	201094-1	Panel, Decorative Vinyl. See Page 29.
5	340054-33	Trim, Inside Horizontal.
6	340054-13	Trim, Inside Vertical.
7	341053	Trim, Outside Vertical, Right or Left
8	440162	Window, Front.
9	340054-11	Trim, Inside Horizontal.
10	640012	Bottom Hinge Assembly.
11	340055-6	Trim, Outside Horizontal, Bottom.
12	603349	Trim, Coin Return Cup.
13	201156	Door, Coin Return Cup.
14	420071	Lock, w/2 Keys. Specify Number.
	420071-1	Ace Lock, w/1 Key.
	420071-2	Ace Lock, w/0 Key.
15	640089	Assembly Complete Lock Handle.
16	610317	Trim, Main Button Panel.
17	441225	Selection Button.
18	440222	Glass, Instruction. 58-106-26d.
	440224	Glass, Instruction. 64-106-25e-\$1.30.
19	320046	Lever, Coin Return.
20	600335	Door Only. Specify Color.
21	600358	Trim - G/M Display.
22	440221-1	Glass - G/M Display.
23	400100-1	Product Retainer Wire.

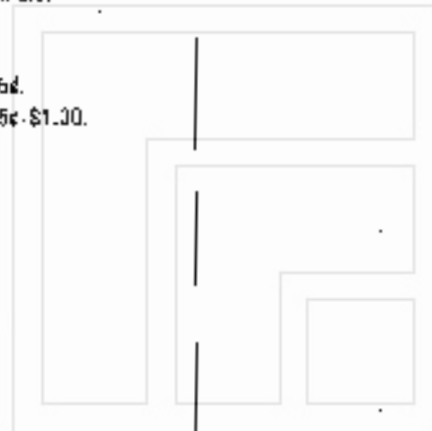

This document is available free of charge to our customers at [www.automaticproducts.com](http://www.automaticproducts.com)

door - inside front

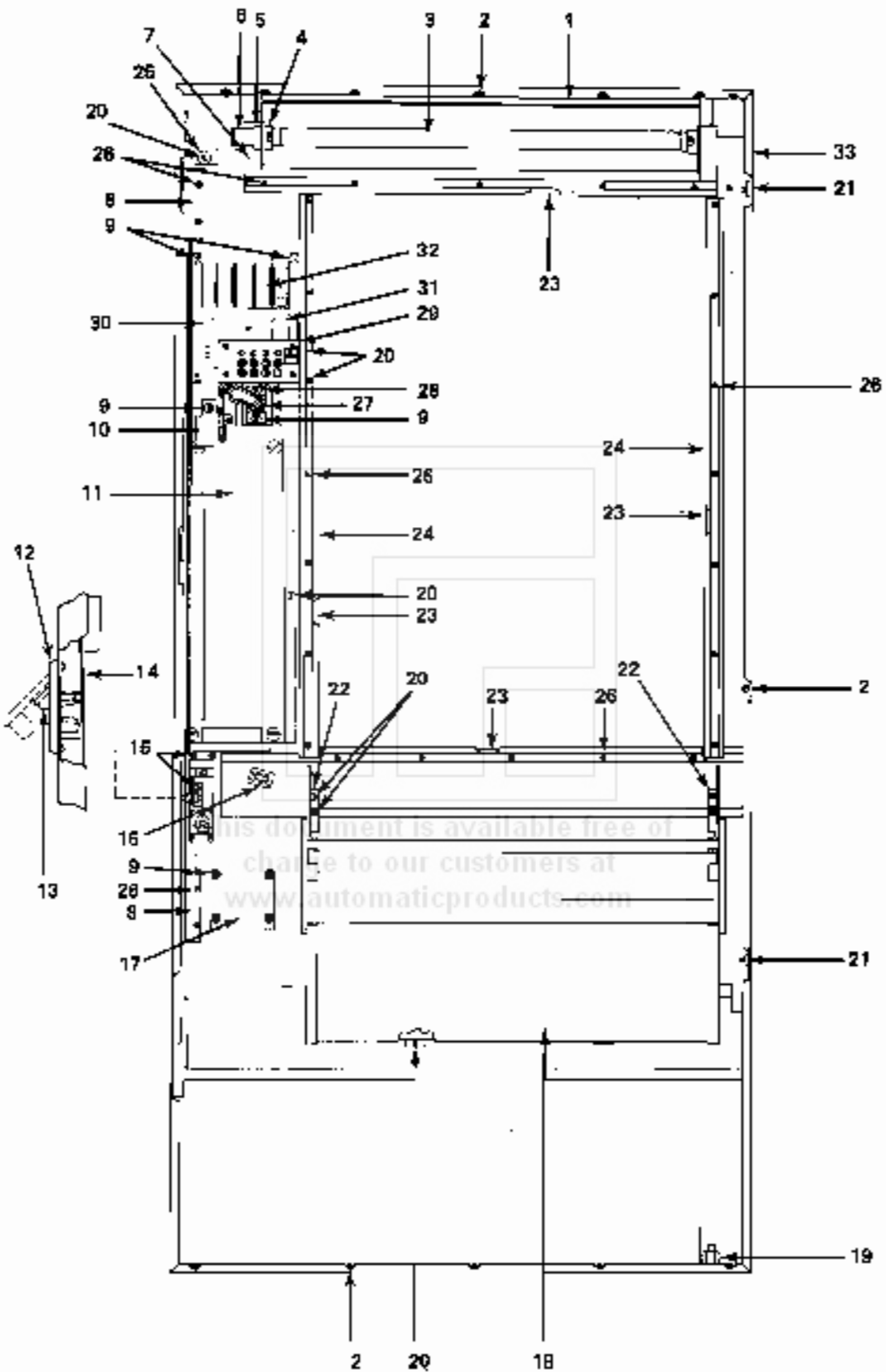

Item No.	Part No.	Description
1	200055-3	Clamp, Illuminated Panel, Upper.
2	200-6R6	Screw, Type A Rd. Hd. Phillips (6 - 1/8 x 3/8).
3	380022-5	Lamp, Fluorescent, F18-T8-K24.
4	380047	Socket, Fluorescent Lamp.
5	380080	Socket, Starter.
	420062-1	Screw, Rd. Hd. Mech. (4 - 3/8 x 3/4).
6	380023	Starter, FS-25.
7	660173-1	Assembly Complete, Lamp Bracket and Harness.
	600241-1	Top Lamp and Window Bracket Only.
8	200973	Bracket, Locking Bar Support.
9	404-B	Nut, Hex Hd. Nu. 8-32.
10	660289	Door Coin Chute, Plastic.
11	660286	Control Board
	660266	Button Panel
	660270	Control Board Cover
	640089	Lock Handle Assembly Complete.
13	200654	Cam, Lock Handle
	420010-7	Washer.
	420070	Roller.
14	600330-1	Door Locking Bar Assembly.
15	335-6R6	Screw, Pan Hd. Phillips Taptite (8-32 x 3/8).
16	420046	Adhesive Back Cable Guide.
17	201155	Coin Return Cup.
	201156	Coin Return Cup Door.

Item No.	Part No.	Description
18	660202	Delivery Bin Assembly Complete. (See Page 26 for Itemized Parts).
19	300151	Nut, Special, Door Stop Anchor.
20	276-6R6	Screw, Pan Hd. Self Tap. (8-32 x 3/8).
21	420097	Card Clip.
22	201180	Delivery Bin Anchor Strip.
23	460150	Insulation, Rubber. (Order Number of Inches Needed).
24	200951	Window Side Shield (Clamp).
25	420029	Rubber Bumper (1" Dia.).
26	201-6R7	Screw, Type B Rd. Hd. Phillips (No. 6 x 7/16 - Used Around Window and Furniture Lock Machines - Top).
27	440175	Coin Return Extension Arm.
	400007	Spring, Coin Return Lever.
28	200795	Coin Extension Arm and Spring Mounting Bracket.
23	660265	Mode Switch Assembly Complete. (See Page 27 for Itemized Parts).
	201127	Mode Switch Box Mounting Bracket.
30	201145-1	G/M Hold Down Bracket - Lock.
31	640111	G/M Hold Down Bracket - Pin.
32	440222	G/M Display Box.
33	600335	Door Only. Specify Color.

This document is available free of charge to our customers at [www.automaticproducts.com](http://www.automaticproducts.com)

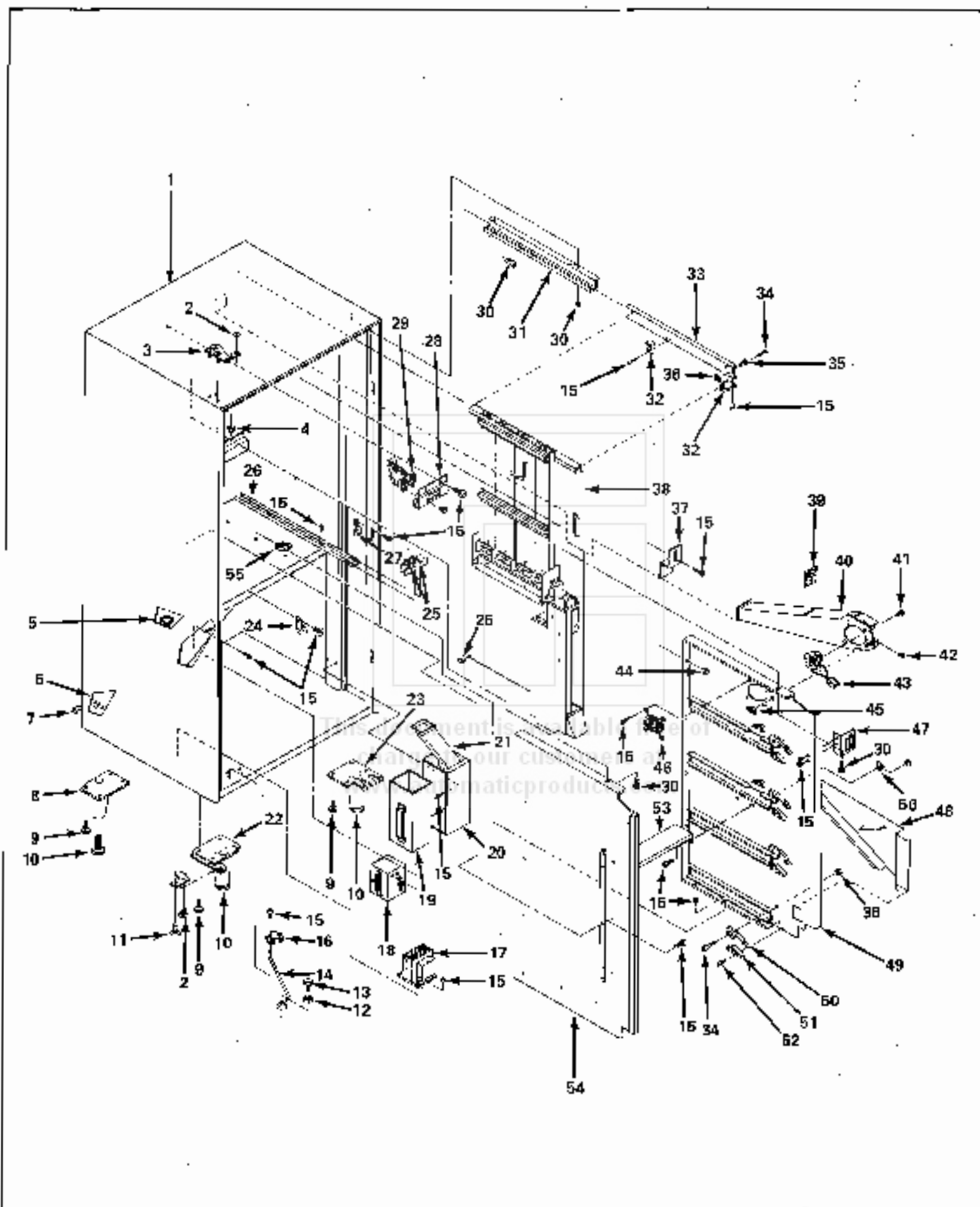

Item No.	Part No.	Description	Item No.	Part No.	Description
1	750191-1	Cabinet Assembly w/ Legs - 5 Shelf, 5000. Spec. by Color.	31	600250-1	Roller Channel Mtg. Bracket.
2	420003-1	Screw, Flat Hd. Allen 1/4 - 20 x 1/2.	32	200816	Roller Channel Stop Bracket.
3	600015-1	Upper Hinge Assembly.	33	600180-1	Assembly, Complete, Roller Channel.
4	438-41	Nut, Keys 1/4 - 20.		201223	Roller Channel Qty.
5	420043-4	Snap Bushing, 1 - 5/16 Dia.	34	300137	Screw, Self Roller.
6	380052	Strain Relief Bushing.	35	440123	Shelf Roller.
7	300037-1	Cord Sec.	36	437-41	Nut, Keys 1/4 - 20.
8	600195	Leg Assembly, Rear.	37	201177-1	Fan Hole Cover.
9	114-51-12	Screw, Hex Hd. Mach. (5/16 - 18 x 3/4).	38	600380	G&M Panel Only. (See Page 2 for Detailed Parts).
10	300103	Leg Leveler.	39	201176	Fan Screen.
11	420003	Screw, Flat Hd. Allen (1/4 - 20 x 3/4).	40	600367	Assembly, Fan Chute Only.
12	420010-10	Washer.		750192	Kit Assembly Complete, Fan and Chute.
13	114-41-3	Screw, Hex Hd. Mach. 1/4 - 20 x 1/2.	41	777-10R6	Screw, Pan Hd. Self Tap (10 - 32 x 3/8).
14	400090	Door Stop.	42	420040-6	Snap Bushing.
15	276-6R6	Screw, Pan Hd. Self Tap. (8 - 32 x 3/8).	43	680276	Assembly, Fan Termination.
16	200040	Door Stop Bracket.	44	404-6	Nut (8-32).
17	360193	Transformer, 115V to 12V and 28V.	45	420023	Wing Nut, (8 - 32).
18	680270	Bracket, Circuit Breaker and Ballast Mtg. (See Page 28 for Detailed Parts).	46	390215	Fan Finger Guard.
19	600179-1	Cash Box, Large.	47	60013-1	Actuator, Mode Switch Assembly.
20	600313-1	Cash Box Mounting Bracket.	48	300797-2	G/M Delivery Chute.
21	300366	Cash Box Coin Chute.	49	600355	Right Side Panel only, 5 Shelf.
22	600196	Leg, Front, Hinge Side.		600273	Assembly Complete, Right Side Panel, 5 Shelf.
23	600197	Leg Assembly, Front Lock Side.	50	440101	Shelf Lock.
24	476088	Speed Clamp.	51	440130	Front Roller Guide.
25	440323	Rivet, Nylon Guide.		440242	Front Roller Guide, Large.
26	201225	Lower S/M Guide Channel.	52	276-8R12	Screw, Pan Hd. Self Tap (8 - 32 x 3/4).
27	200374-1	Door Lock Catch.	53	200833-1	Spacer, Right to Left Side Panels.
	600310-1	Door Lock Catch, Heavy Duty.	54	600357	Left Side Panel Only, 5 Shelf.
28	201136	Receptacle Mounting Bracket.		660275	Assembly Complete, Left Side Panel, 5 Shelf.
29	380039	Main Product Self Receptacle.	55	420030	Grommet, 7-7/16 Long.
30	277-16R8	Screw, Pan Hd. Self Tap (10 - 32 x 1/2).	56	201257	Diverter, G & M.

# gum & mint sliding panel

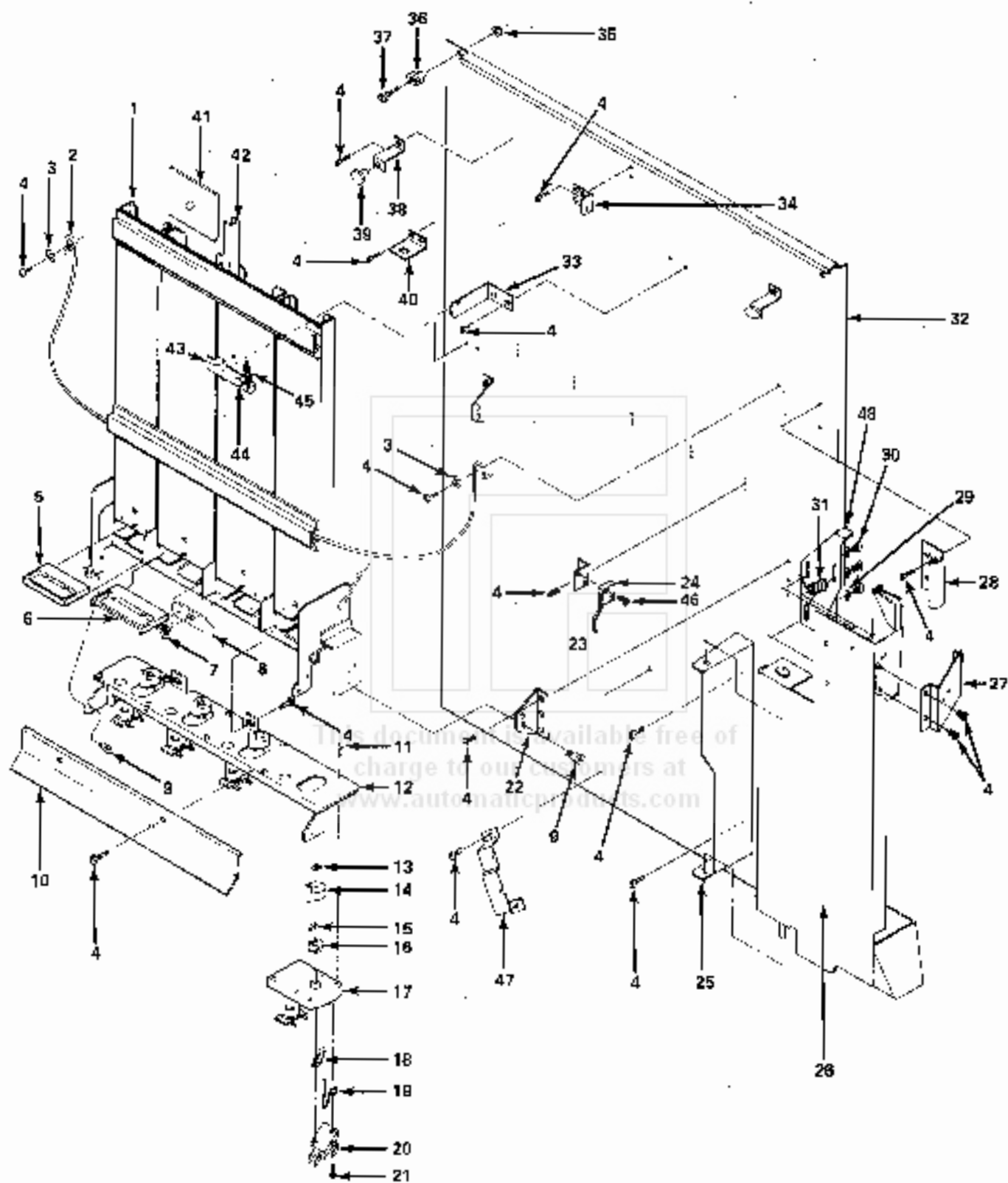



Item No.	Part No.	Description	Item No.	Part No.	Description
1	660237	Ass'y. Complete G & M Stack with Motors,	26	660287	Ass'y. Complete Coin Changer
	600381	G & M Stack Only.			Mounting Bracket.
7	400084	G & M Cash Support.		600375	Changer Mounting Bracket Only.
8	420024	Washer, Star.		420080	Mint Changer (MC-600).
4	276-8R6	Screw, Pan Hd. Self Tap (8-32 x 3/16).		420080-2	Coin Changer (300).
5	440143	Ejector, Narrow Column.		420080-13	Coin Changer (600).
6	440149-1	Ejector, Wide Column.	27	640115	Ass'y. Changer Latching Bracket.
7	420023	Nut, Wing (No. 8).	28	200580-1	Handle.
8	200980	Adapter, G & M.	23	420110-4	Washer.
3	300150	Screw, Shoulder. Motor Mount (Van.).	30	11E-8RG	Screw, Pan Hd. Mech. Phillips
10	231226	G & M Deflector.			(8-32 x 3/8).
11	335-8R6	Screw, Pan Hd. Taptite Phillips (8-32 x 3/8).	31	430098	Spring, Coin Return Arm Bracket.
12	701230	Motor Mount, G & M.	32	600280	G & M Panel Only.
13	751-71	Ring, Retaining (No. 21).	33	200814	G & M Stack Catch.
14	440151	Clutch, Head Crank.	34	200816	Bracket, Roller Channel Stop.
15	400079	Spring, G & M Motor Clutch.	36	437-41	Nut, Keys (W - 28).
16	440153	Clutch Post.	36	440123	Roller.
17	750106-1	Ass'y. Complete, G & M Motor 24 Volt.	37	300137	Roller Screw.
18	320050	Brake, Die Cast.	38	203615	Bracket, G & M Stack Spacer.
19	400072	Spring.	39	420008	Roller Bearing.
20	380160	Switch.	40	201126	Receptacle Mounting Bracket.
21	100-4-3	Screw, Rd. Hd. Mech. (4-40 x 9/16).	41	440051	Adapter, Plastic, For 71 in Mints.
22	200918	G & M Price Bracket.	42	203132-2	Spacer, G & M Column (2 per wing col.).
23	200818	Mounting Bracket, G & M Empty Switch.	43	200131	Latch, G & M Stack.
24	650177	Ass'y. Switch and Bracket.	44	300343	Rivet.
	380100	Switch, G & M Empty.	45	400320	Spring, Column Latch.
25	600377	Changer Hanging Support Bracket.	46	256-4R3	Screw, Pan Hd. Type 1 Phillips (4 x 9/16).
			47	731130	Changer Screw Mounting Bracket.
			48	231131	Coin Return Silica Arm.

This document is available free of charge to our customers at [www.automaticproducts.com](http://www.automaticproducts.com)

Item No.	Part No.	Description	Item No.	Part No.	Description
18	630238	Candy Shelf.	29	630191-3	Product Rail Assy. For use w/ Snack Spiral.
19	660746-1	Product Guide.	31	680259	Ass'y. Complete Candy Shelf Harness.
20	600265	7 1/2 Space Candy Spiral.	32	1004-9	Screw, Rd. Hd. Mach. 1/4-20 x 9/16.
	300265-1	16 Space Candy Spiral.	33	750363-1	Kt. Can Dispenser Assy.
	500265-2	12 Space Candy Spiral.	34	440291	Drive Cam, Rear.
	600265-3	10 Space Candy Spiral.	35	Retaining Ring, #31.	
	830265-4	8 Space Candy Spiral.	36	440263	Drive Cam, Front.
21	440111	Candy Product Pusher.	37	540109	Can. Main Line Brkt. & Spring Assy.
22	600178-7	Candy Spacer Assy.	38	600308-1	Can Dispenser, Trough Only.
23	440127	Price & Selection Tab Holder.	39	330034	Shoulder Screw.
24	440176	Spiral Retainer Only.	40	410091-1	Actuator Wire.
25	390-30	Switch.	41	440196	Price and Selection Trim.
26	130072	Spring.	42	740199	Strip Lever.
27	520050	Brake, Mfg. Cast.	43	440108	Leg, Top Car Guide & Sign Trim.
28	420097	Screw, Drive #8 - Type LL.	44	440197	Top Car Guide & Sign Trim.
29	660191-2	Product Rail Assy. For use w/ Candy Spiral.			

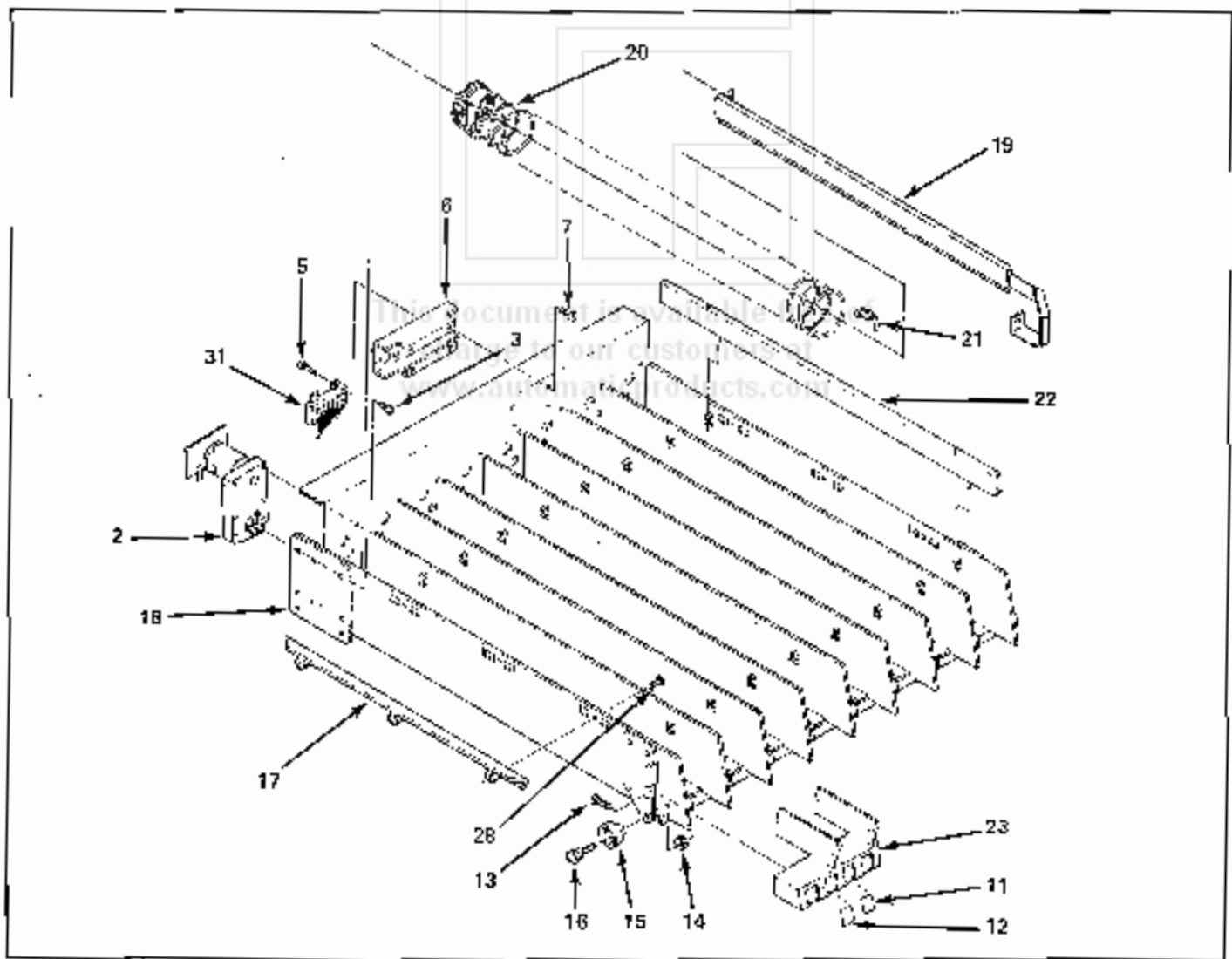

# delivery bin

Item No.	Part No.	Description
1	660202	Delivery Bin Ass'y. Complete.
2	600277	Delivery Bin.
3	640099	Arm Mounting Bracket (Lock Side).
4	433-3	Nut, Caps. No. 8-32.
5	640098	Inner Door Bin Arm.
6	640100	Bin Door Drive Ass'y. (Lock Side)
7	751-37	Retaining Ring No. 37
8	276 BR6	Screw, Pan Hd. Philips. Self Tap. No. 8-32 x 3/8"
9	640097	Door Drive Arm.

Item No.	Part No.	Description
9	440178	Door Bearing.
10	640092-1	Inner Door.
12	600758-1	Floor, Delivery Bin.
13	420029	Rubber Bumper.
14	640100-1	Bin Door Drive Ass'y. (Pivot Side)
15	640099-1	Arm Mounting Bracket. (Pivot Side)
16	200992-1	Baffle, Rear Delivery Bin.
17	2C1180	Delivery Bin Anchor Strap.
18	660238-1	Delivery Bin Pan Ass'y. For Can Dispenser.

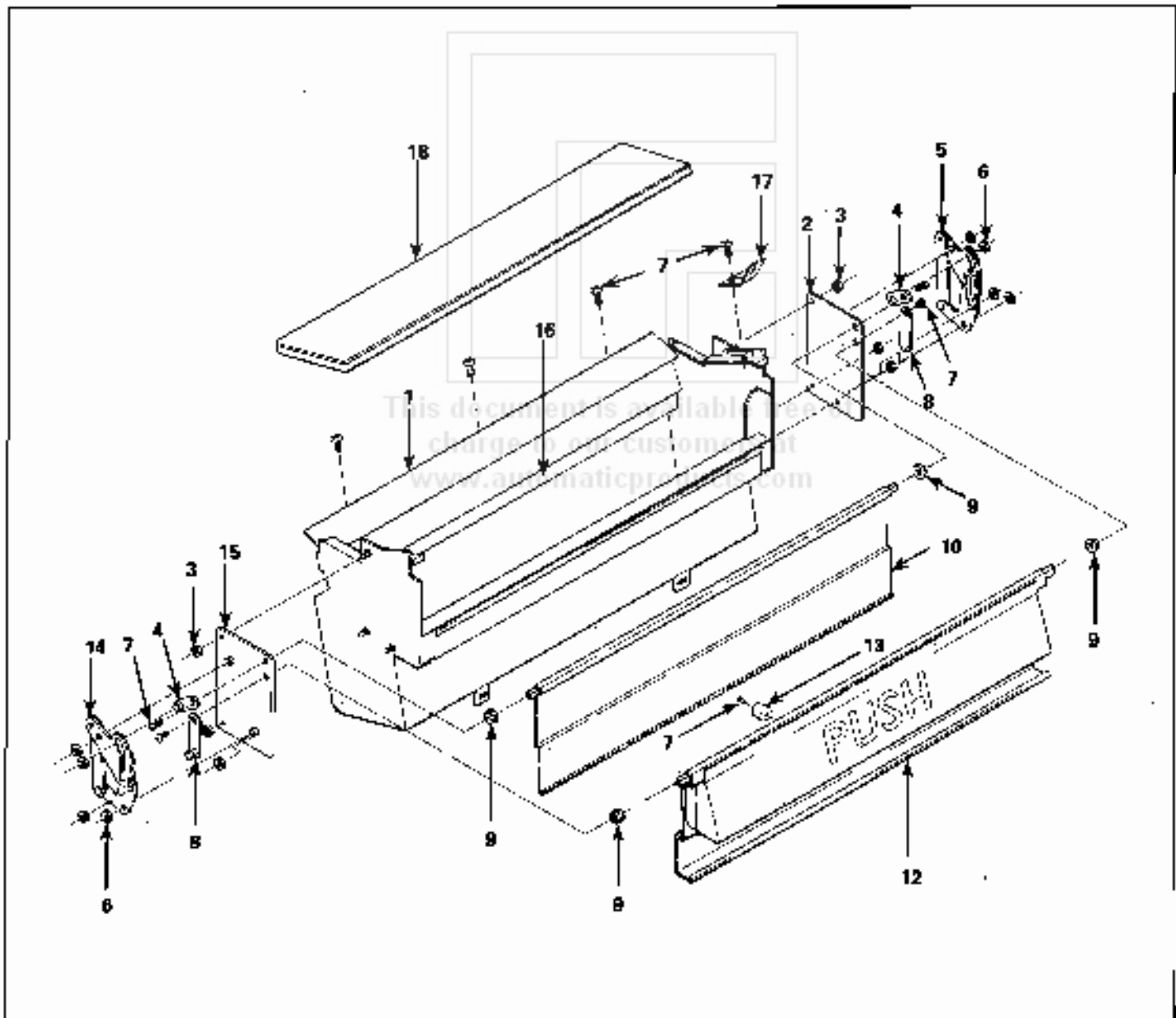

# main button and panel assembly

Item No.	Part No.	Description
1	320016	Coin Return Lever
2	660281	Assembly Complete, Button Trim & Panel
	600347	Trim, Coin Button Only
3	201147	Coin Return Lever Back Plate
4	440227	Spacer, Coin Extension Arm Bracket
5	730795	Coin Extension Arm/Spring Bracket
6	404-8	Hex Nut (8-32)
7	400067	Spring, Coin Return Lever
8	440175	Coin Return Extension Arm
9	335-8R6	Screw, Pan Hd. Tap-Tite 18-32 x 3/8
10	660268	Harness, Made Switch Box
11	404-6	Hex Nut 18-32
12	660266-1	Assembly Made Switch Box
13	420122	Spacer, Made Switch Board
14	201127	Made Switch Bracket Only
15	276-8R6	Screw, Pan Hd. Self-Tap 18-32 x 3/8
16	100-6R12	Screw, Round Hd. 18-32 x 3/4
17	420121	Hide Plug
18	201-6R6	Screw, Rd. Hd. Phillips 18-18 x 3/8
19	440230	Plastic Support

Item No.	Part No.	Description
20	300161	Board Spacer, Long
21	201204	Board Spacer Lock
22	660293	Assembly Control Board Cover
	201250	Control Board Cover Only
23	660289	Door Coin Chute Plastic
24	420126	Retainer
25	300159	Shoulder Screw
26	420130	Nut, Serrated Flange 18-32
27	480283	Rubber Grommet
28	660297	Assembly, Complete Control Board w/Plastic Support
	660295	Control Board, Lower Part Only
29	300158	Board Spacer
30	360097	Connector Ribbon
31	660294	Board, Digital Display only w/Plastic Support
32	751-18	Retaining Ring
33	660266	Assy, Complete, Selector Switch Panel
34	440225	Selector Button
35	440273	Coin Instruction Glass 5-10-25
	440274	Coin Instruction Glass 5-10-25-\$1.00

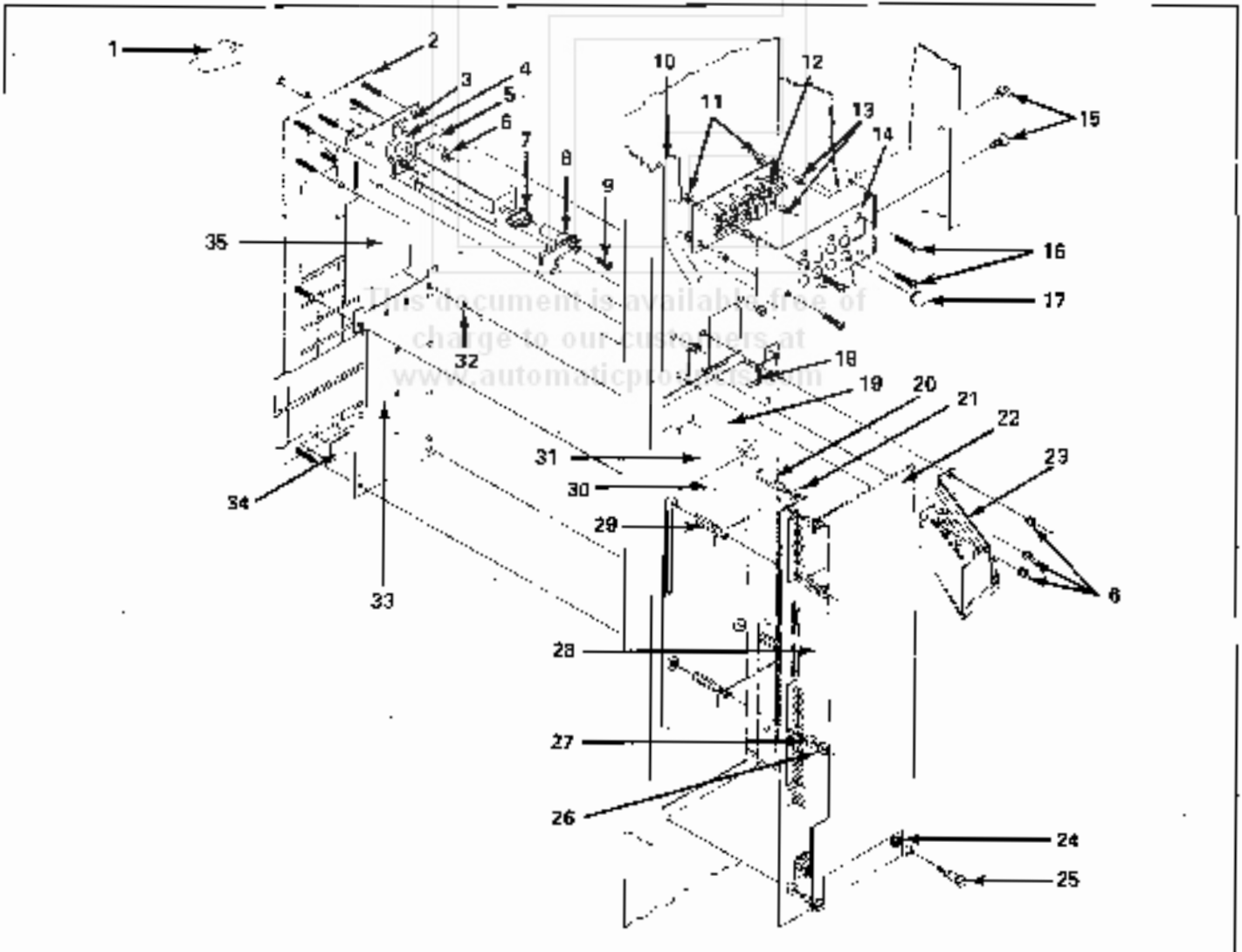

## main interlock box

Item No.	Part No.	Description
1	201153 680270	Bracket, Ballast and Switch Enclosed Only. Assembly Complete.
2	390101-1	Circuit Breaker, w/Nut 3 Amp.
3	380126	Toggle Switch w/Nut.
4	380159	2 Pin Molex Receptacle.
5	201153	Bracket, Ballast and Switch Bracket
6	276-6R4	Screw, Pan Hd. No. 6-32 x 1/4".
7	380107	6 Pin Molex Receptacle.
8	380135	3 Pin Molex Receptacle.

Item No.	Part No.	Description
9	380034	3 Pin Molex Plug.
10	380106	6 Pin Molex Plug.
11	276-6H4	Screw, Pan Hd. No. 6-32 x 1/4".
12	680074 680278	Ballast Assy. Complete, Ballast.
13	680269	Under Shelf Harness. (not shown)
14	200-6R6	Screw, Type A Pan Hd. No. 6 x 3/8".

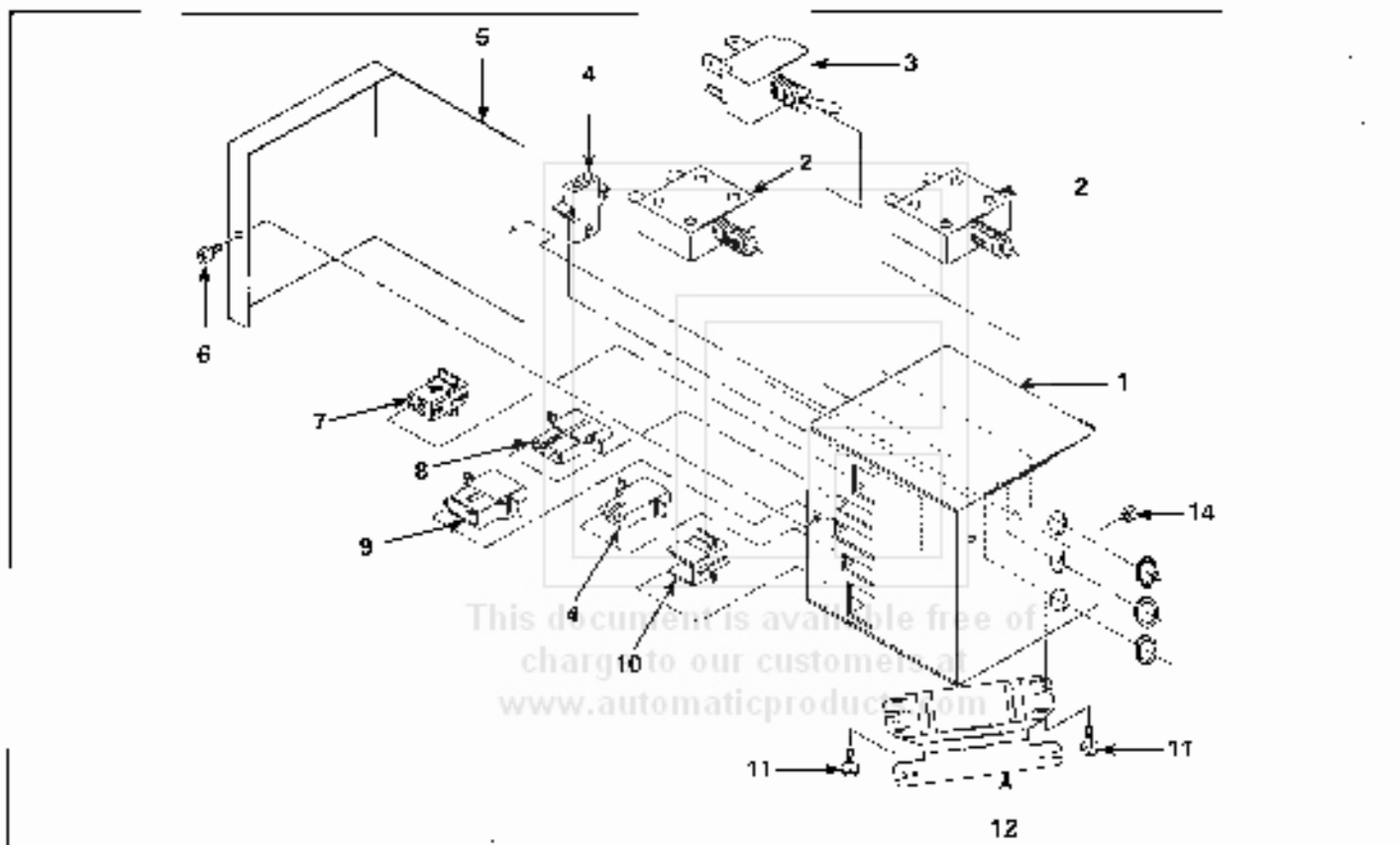

## electrical harnesses

Part No.	Description
680139	Lamp Harness Assembly
680139-2	Light Cord Harness (Near to Cabinet) (Long)
680139-3	Light Cord Harness (Short)
680268	Pantry Shelf Harness
680269	Candy Shelf Harness
380086	Cord Set.

Part No.	Description
680263	Cabinet Jack Harness (Short)
680268	Mode Switch Board Harness
680269	Under Shelf Harness
680271	Under Shelf Harness Assembly
680275	Fan Cord Harness
680263	Mars & Corinto Changer Harness.
680281	Gum & Mint Harness.

door - A.P. style - panels

Item No.	Part No.	Description
1	201034	<b>Plate, Cover Up.</b> Painted. Specify Color.
	201034-1	Presidential Walnut Vinyl.
	201034-2	Honeytone Teak Vinyl.
	201034-3	Regency Walnut Vinyl.
	201034-4	Kashmir Walnut Vinyl.
	201034-5	Imperial Rosewood Vinyl.
	201034-6	Spanish Oak Vinyl.
2	200792-7	<b>Panel, Left Side Vertical.</b> Presidential Walnut Vinyl.
	200792-8	Imperial Rosewood Vinyl.
	200792-9	Honeytone Teak Vinyl.
	200792-10	Regency Walnut Vinyl.
	200792-11	Kashmir Walnut Vinyl.
	200792-12	Painted. Specify Color.
	200792-14	Spanish Oak Vinyl.
3	200793-8	<b>Panel, Vinyl. Delivery Tray.</b> Presidential Walnut Vinyl.
	200793-9	Imperial Rosewood Vinyl.
	200793-10	Honeytone Teak Vinyl.
	200793-11	Regency Walnut Vinyl.
	200793-12	Kashmir Walnut Vinyl.
	200793-13	Painted. Specify Color.
	200793-14	Spanish Oak Vinyl.
4	200296-43	<b>Panel, Lower Horizontal.</b> Presidential Walnut Vinyl.
	200296-44	Regency Walnut Vinyl.
	200296-45	Kashmir Walnut Vinyl.
	200296-46	Honeytone Teak Vinyl.
	200296-47	Spanish Oak Vinyl.
	200296-48	Imperial Rosewood Vinyl.
	200296-49	Painted. Specify Color.
5	201222	<b>Panel, Right Side Vertical.</b> Presidential Walnut Vinyl w/o G&M.
	201222-1	Regency Walnut Vinyl w/o G&M.
	201222-2	Kashmir Walnut Vinyl w/o G&M.
	201222-3	Honeytone Teak Vinyl w/o G&M.
	201222-4	Spanish Oak Vinyl w/o G&M.
	201222-5	Imperial Rosewood Vinyl w/o G&M.
	201222-6	Painted. Specify Color. w/o G&M.
	201222-7	Presidential Walnut Vinyl w/G&M.
	201222-8	Regency Walnut Vinyl w/G&M.
	201222-9	Kashmir Walnut Vinyl w/G&M.
	201222-10	Honeytone Teak Vinyl w/G&M.
	201222-11	Spanish Oak Vinyl w/G&M.
	201222-12	Imperial Rosewood Vinyl w/G&M.
	201222-13	Painted. Spec. Color. w/G&M.
6	600335	Door, Only. Specify Color.

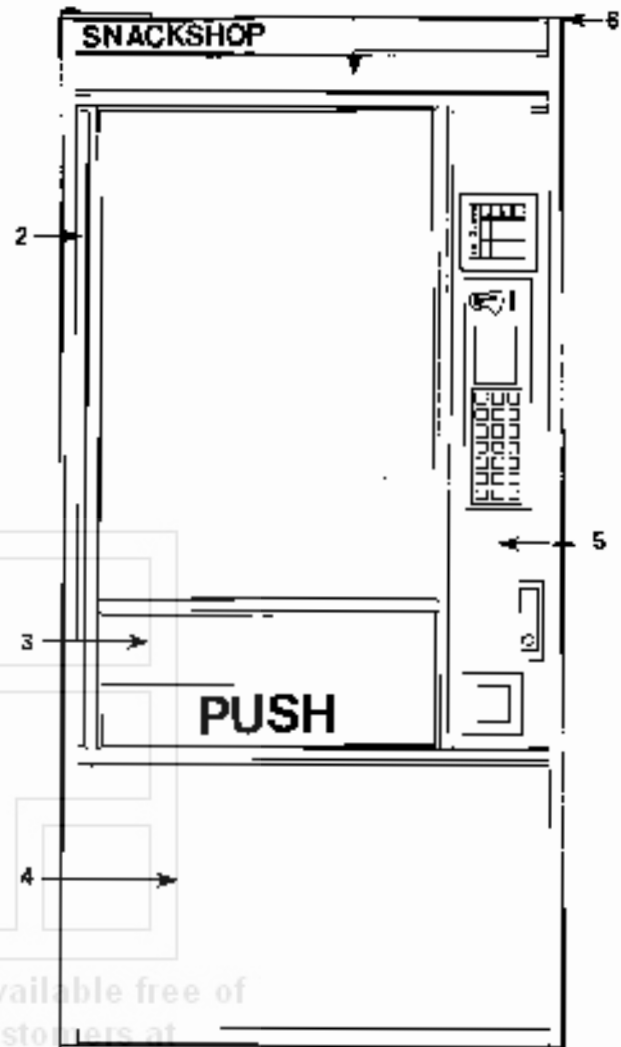

This document is available free of charge to our customers at [www.automaticproducts.com](http://www.automaticproducts.com)

# crowns style

Item No.	Part No.	Description
1	340065-0	Trim, Outside Horizontal, Top or Bottom.
2	201094-1	Plate, Cover Up, Presidential Walnut.
3	340054-33	Trim, Inside Horizontal.
4	340054-13	Trim, Inside Vertical.
5	200792-7	Panel, Left Side Vertical.
6	340053	Trim, Outside Vertical, Right or Left.
7	340054-11	Trim, Inside Horizontal.
8	200793-8	Panel, De-icing Tray, Presidential Walnut.
9	200298-43	Panel, Lower Horizontal, Presidential Walnut.
10	201222	Panel, Right Side Vertical, w/o G&M, Presidential Walnut.
	201222-7	Panel, Right Side Vertical w/G&M, Presidential Walnut.
11	800335	Door, Du y. Specify Color.

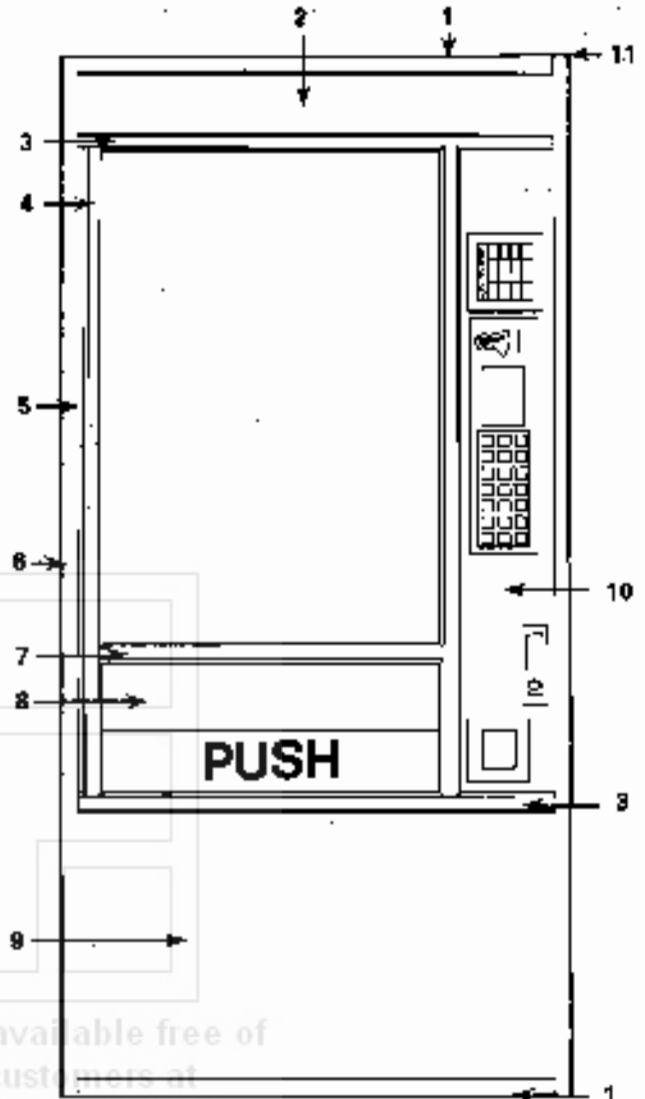

This document is available free of charge to our customers at [www.automaticproducts.com](http://www.automaticproducts.com)

Item No.	Part No.	Description
1	340055-7	Trim, Outside Horizontal, Top or Bottom, Bronze.
2	201094-1	Plate, Cover Up, Presidential Walnut.
3	340054-34	Trim, Inside Horizontal, Bronze.
4	200792-7	Panel, Left Side Vertical, Presidential Walnut.
5	340054-18	Trim, Inside Vertical, Right or Left, Bronze.
6	340054-17	Trim, Inside Horizontal, Bronze.
7	200793-8	Panel, Delivery Tray, Presidential Walnut.
8	340053-2	Trim, Outside Vertical, Right or Left, Bronze.
9	200296-43	Panel, Lower Horizontal, Presidential Walnut.
10	201222	Panel, Right Side Vertical w/o G&M, Presidential Walnut.
	201222-7	Panel, Right Side Vertical w/G&M, Presidential Walnut.
11	600335	Door, On'y. Specify Color.

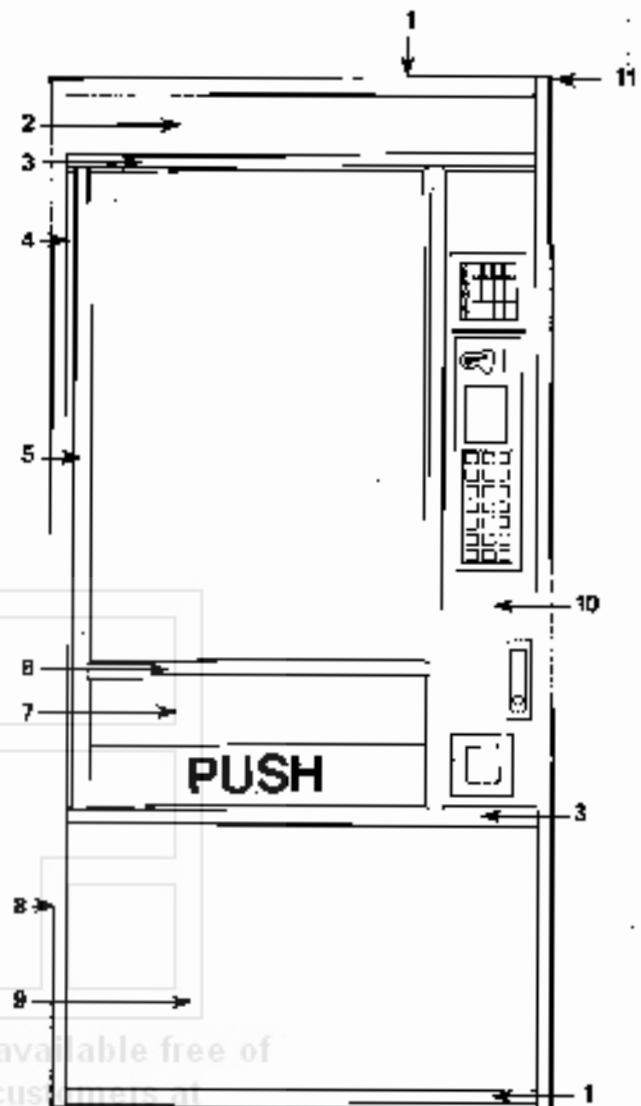

This document is available free of charge to our customers at [www.automaticproducts.com](http://www.automaticproducts.com)



# imperial style

Item No.	Part No.	Description
1	660231-18	Trim, Outside Horizontal, Top or Bottom, w/Black Strips.
2	440159	Frame, Plastic.
	211-8R4	Screw, Truss Hd. Phillips Type B (8 x 1/2)
3	440154	Panel, Insert.
4	201094-7	Cover Up Piece, Presidential Walnut.
5	660231-17	Trim, Inside Horizontal, w/Black Strips.
6	340054-13	Trim, Inside Vertical, Right or Left.
7	200792-7	Panel, Left Side Vertical, Presidential Walnut.
	660216-5	Panel, Left Side Vertical, Burlap.
8	340053	Trim, Outside Vertical, Right or Left.
9	340054-11	Trim, Inside Horizontal.
10	200793-8	Panel, Delivery Tray, Presidential Walnut.
11	200296-43	Panel, Lower Horizontal, Presidential Walnut.
12	201222	Panel, Right Side Vertical w/o G&M, Presidential Walnut.
	660217-19	Panel, Right Side Vertical, Burlap, w/o G&M.
	201222-7	Panel, Right Side Vertical w/G&M, Presidential Walnut.
	660217-20	Panel, Right Side Vert. Burlap w/G&M.
13	600335	Door Only. Specify Color.

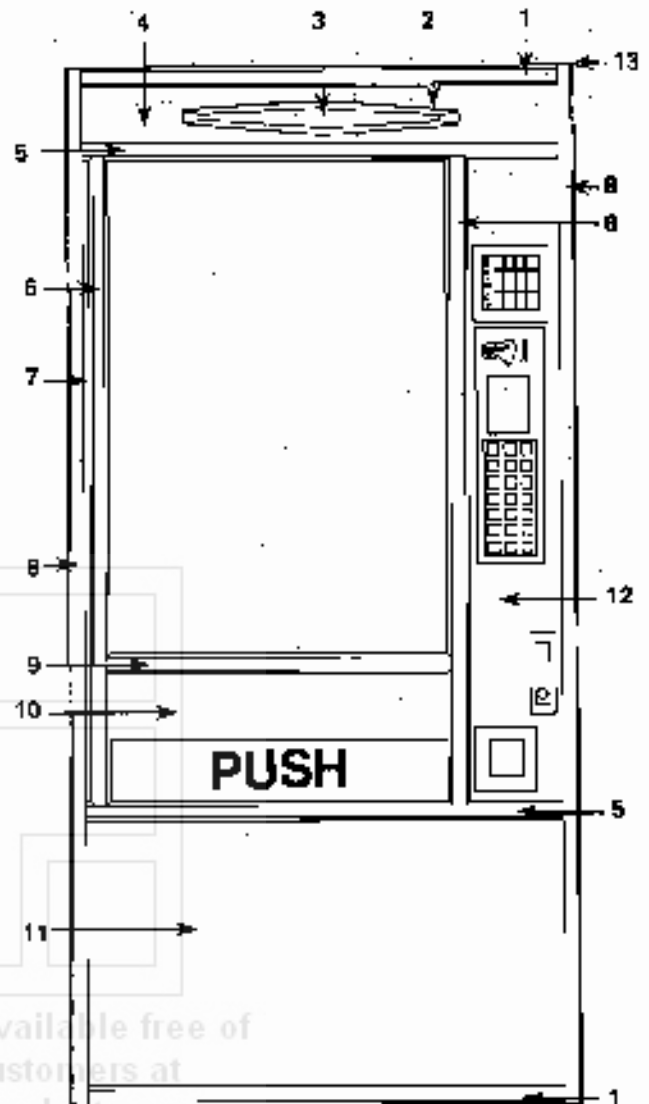

This document is available free of charge to our customers at [www.automatproducts.com](http://www.automatproducts.com)

Item No.	Part No.	Description
1	660231-19	Trim, Outside Horizontal, Top or Bottom. Bronze. w/Black Stripe
2	440188-3	Frame, Top Trim.
3	440189	Frame, Top Inner.
4	440174	Frame, Top Inner Insert.
5	660226-3	Panel, Decorative Assy. (Cane).
6	340054-23	Trim, Inside Vertical. Bronze. (Right or Left).
7	263782-7	Panel, Left Side Vertical. Presidential Walnut.
8	340053-2	Trim, Outside Vertical. Bronze. (Right or Left).
9	340054-17	Trim, Inside Horizontal. Bronze.
10	200793-8	Pane, Delivery Tray. Presidential Walnut.
11	200296-50	Panel, Lower Horizontal. Presidential Walnut.
12	440170-3	Frame, Bottom.
	201-6R6	Screw, Rd. Hd. Phillips (6-18 x 5/16).
	201-6R7	Screw, Rd. Hd. Phillips (6-18 x 7/16).
13	660227-3	Panel, Lower Horizontal. (Cane).
14	480237	Handle, Deco.
15	201222	Panel, Right Side Vertical w/o G&M. Presidential Walnut.
	201222-7	Panel, Right Side Vertical w/ G&M. Presidential Walnut.
16	60033E	Door only. Specify Color.

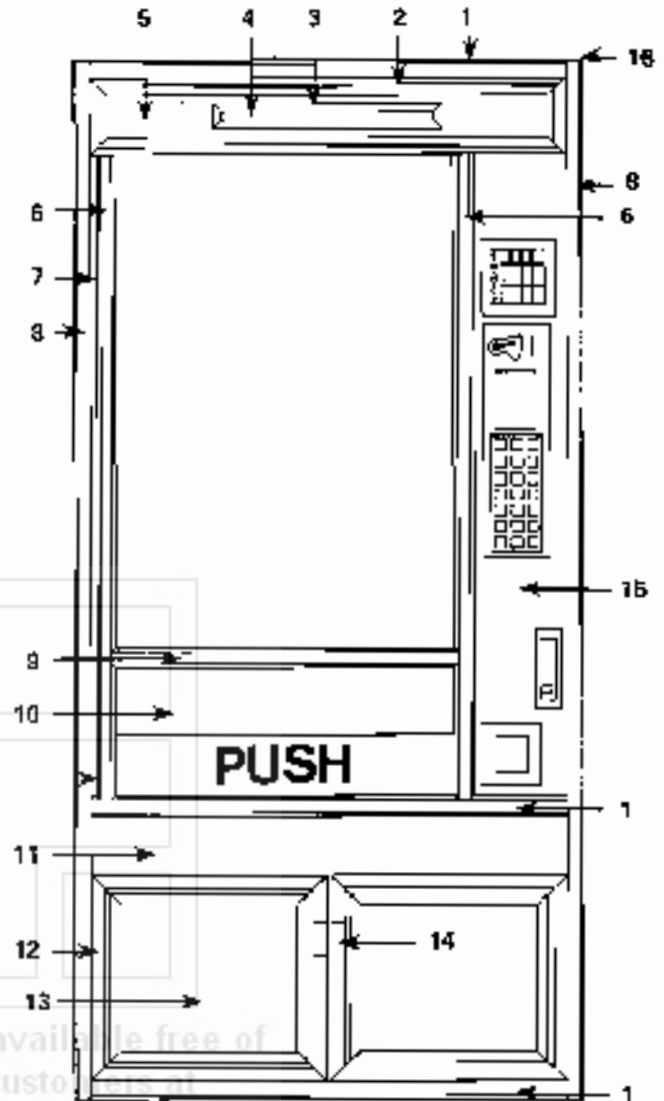

This document is available free of charge to our customers at [www.automaticproducts.com](http://www.automaticproducts.com)

## award style

Item No.	Part No.	Description
1	340042-6	Trim, Top Only.
2	200526-7	Vinyl, Insert, Top Trim, Honeytone Teak.
	200526-8	Vinyl, Insert, Top Trim, Imperial Rosewood.
3	201094-2	Plate, Cover Up, Honeytone Teak.
	201094-5	Plate, Cover Up, Imperial Rosewood.
4	340054-35	Trim, Inside Horizontal, Black.
5	340054-21	Trim, Inside Vertical, Black, Right or Left.
6	200792-8	Panel, Left Side Vertical, Imperial Rosewood.
	200792-9	Panel, Left Side Vertical, Honeytone Teak.
7	660231-10	Trim, Outside Vertical, W/Black Stripe, Right or Left.
8	340054-20	Trim, Inside Horizontal, Back.
9	200793-9	Panel, Delivery Tray, Imperial Rosewood.
	200793-10	Panel, Delivery Tray, Honeytone Teak.
10	200720-31	Panel, Lower Horizontal, Honeytone Teak.
	200720-33	Panel, Lower Horizontal, Imperial Rosewood.
11	201222-3	Panel, Right Side Vertical w/o G&M, Honeytone Teak.
	201222-5	Panel, Right Side Vertical w/o G&M, Imperial Rosewood.
	201222-6	Panel, Right Side Vertical w/o G&M, Painted, Specify Color.
	201222-10	Panel, Right Side Vertical w/ G&M, Honeytone Teak.
	201222-12	Panel, Right Side Vertical w/ G&M, Imperial Rosewood.
	201222-13	Panel, Right Side Vertical w/ G&M, Painted, Specify Color.
12	600335	Door Only, Specify Color.

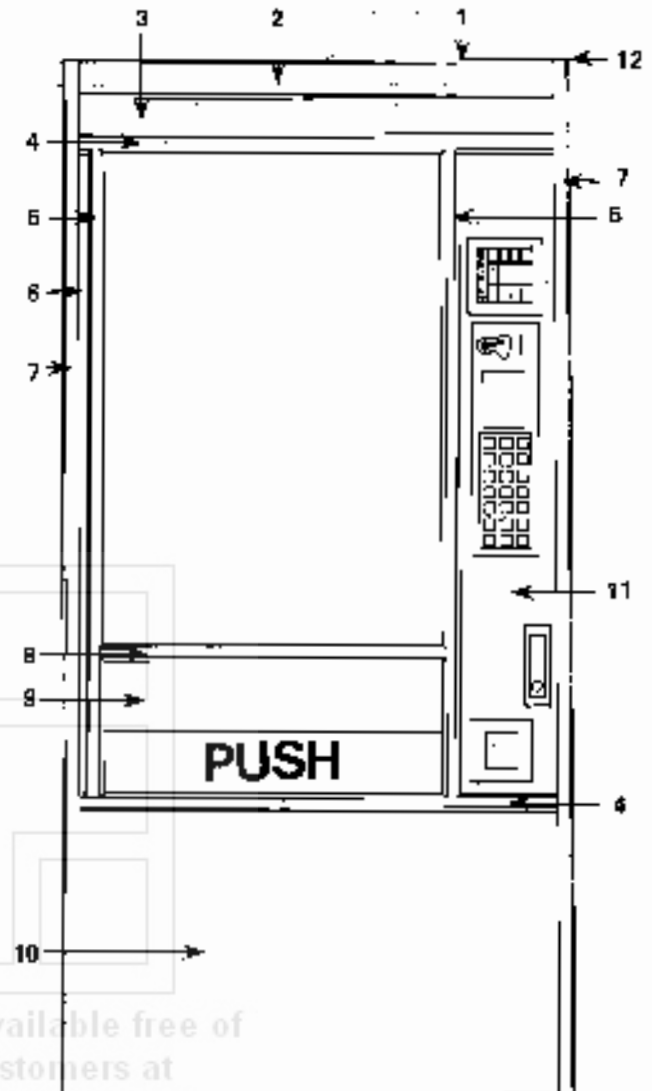

## wheatstone style

Item No.	Part No.	Description
1	340042-7	Trim, Top Only.
2	660220-3	Vinyl, Insert, Top Trim, Wheatstone.
3	660221-11	Plate, Cover Up, Bronze.
4	340054-34	Trim, Inside Horizontal.
5	340054-18	Trim, Inside Vertical.
6	660216-2	Panel, Left Side Vertical, Bronze.
7	340053-2	Trim, Outside Vertical, Right or Left.

Item No.	Part No.	Description
8	340054-17	Trim, Inside Horizontal.
9	660219-1	Panel, Delivery Tray, Bronze.
10	660218-4	Panel, Lower Horizontal, Wheatstone.
11	660217-21	Panel, Right Side Vertical w/o G & M Bronze.
	660217-27	Panel, Right Side Vertical w/ G & M Bronze.
12	600335	Door Only, Specify Color.

Item No.	Part No.	Description
1	340040-3	Trim, Top Only.
2	201284	Plate, Cover Up, Painted, Specify Color.
	201284-1	Plate, Cover Up, Presidential Walnut.
	201094-2	Plate, Cover Up, Honeytone Teak.
	201094-3	Plate, Cover Up, Regency Walnut.
	201094-6	Plate, Cover Up, Spanish Oak.
3	340051-33	Trim, Inside Horizontal.
4	340054-13	Trim, Inside Vertical, Right or Left.
6	200792-7	Panel, Left Side Vertical, Presidential Walnut.
	200792-9	Panel, Left Side Vertical, Honeytone Teak.
	200792-10	Panel, Left Side Vertical, Regency Walnut.
	200792-12	Panel, Left Side Vertical, Painted, Specify Color.
	200792-14	Panel, Left Side Vertical, Spanish Oak.
6	340053	Trim, Outside Vertical, Right and Left.
7	340054-11	Trim, Inside Horizontal.
8	200793-8	Panel, Delivery Tray, Presidential Walnut.
	200793-10	Panel, Delivery Tray, Honeytone Teak.
	200793-11	Panel, Delivery Tray, Regency Walnut.
	200793-13	Panel, Delivery Tray, Painted, Specify Color.
	200793-14	Panel, Delivery Tray, Spanish Oak.
9	200720-28	Panel, Lower Horizontal, Presidential Walnut.
	200720-29	Panel, Lower Horizontal, Regency Walnut.
	200720-31	Panel, Lower Horizontal, Honeytone Teak.
	200720-32	Panel, Lower Horizontal, Spanish Oak.
	200720-34	Panel, Lower Horizontal, Painted, Specify Color.
10	201222	Panel, Right Side Vertical w/o G&M, Presidential Walnut.
	201222-1	Panel, Right Side Vertical w/o G&M, Regency Walnut.
	201222-3	Panel, Right Side Vertical w/o G&M, Honeytone Teak.
	201222-4	Panel, Right Side Vertical w/o G&M, Spanish Oak.
	201222-6	Panel, Right Side Vertical w/o G&M, Painted, Specify Color.
	201222-7	Panel, Right Side Vertical w/ G&M, Presidential Walnut.
	201222-8	Panel, Right Side Vertical w/ G&M, Regency Walnut.
	201222-10	Panel, Right Side Vertical w/ G&M, Honeytone Teak.
	201222-11	Panel, Right Side Vertical w/ G&M, Spanish Oak.
	201222-13	Panel, Right Side Vertical w/ G&M, Painted, Specify Color.
11	600335	Door Only, Specify Color.

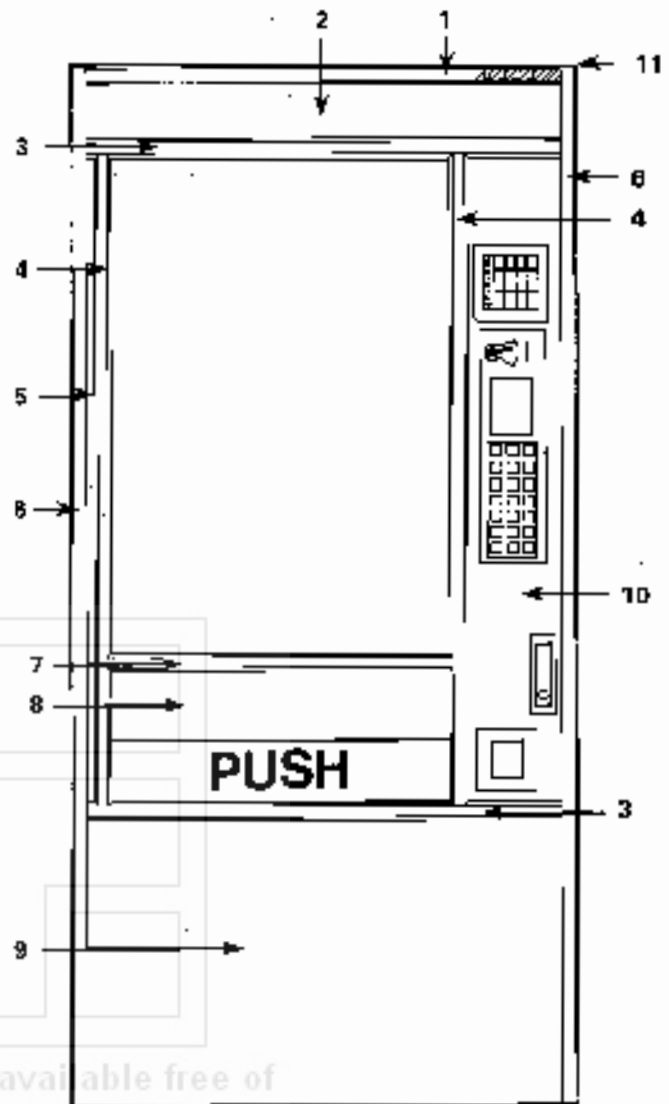

Document is available free of charge to our customers at [www.automaticproducts.com](http://www.automaticproducts.com)



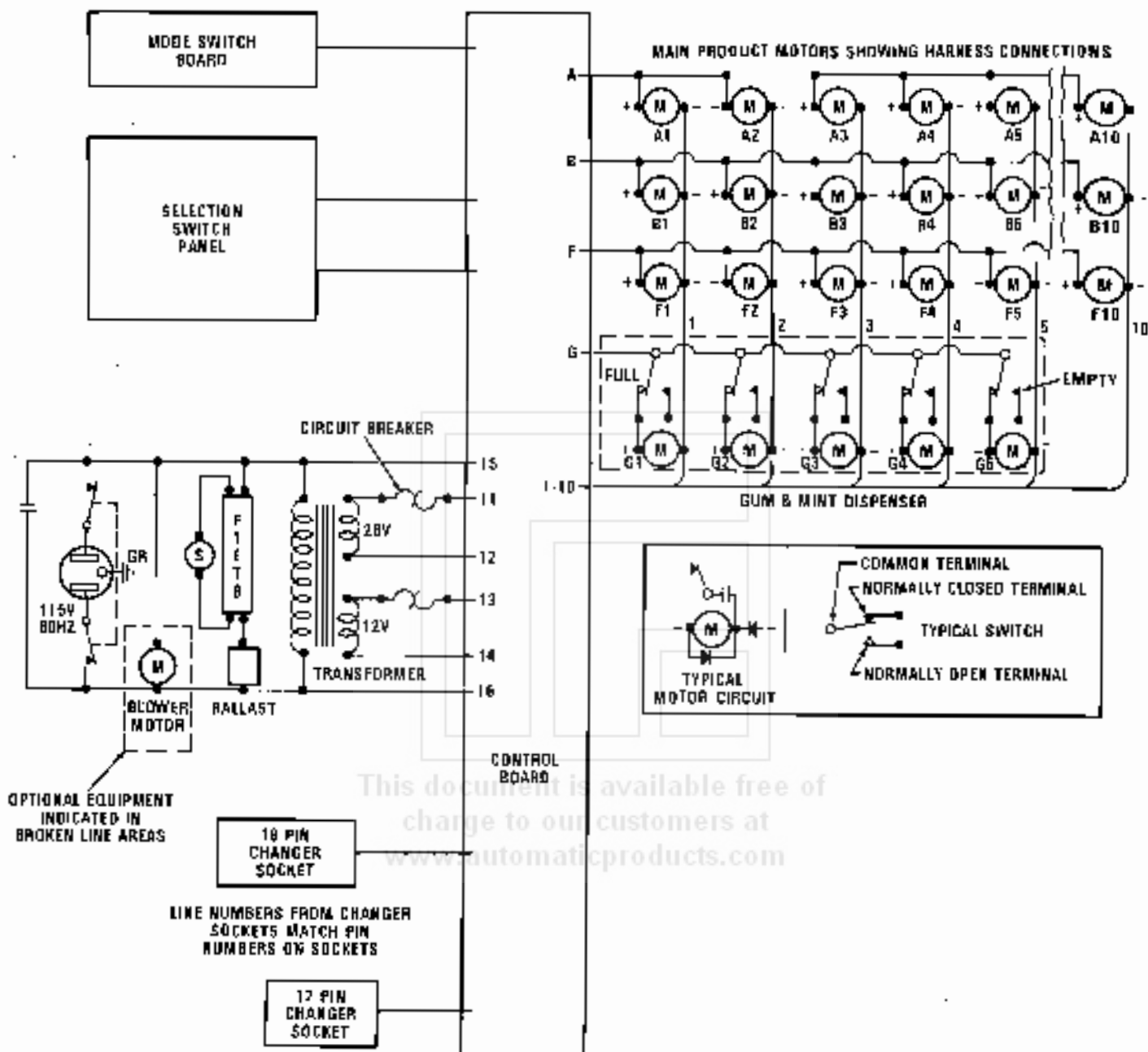

This document is available free of charge to our customers at [www.automatproducts.com](http://www.automatproducts.com)